

Retain this manual
for future reference.

Director's Choice® Tray & Silverware Unit and Rack/Tray Dispensers

OPERATIONS MANUAL & INSTRUCTIONS

CAUTION

INSPECT CONTENTS IMMEDIATELY AND FILE CLAIM WITH DELIVERING CARRIER FOR ANY DAMAGE. **SAVE YOUR BOX AND ALL PACKING MATERIALS.** YOU ARE RESPONSIBLE FOR DAMAGE TO YOUR UNIT IF RETURNED IMPROPERLY PACKED.

MAINTENANCE

Proper cleaning of the unit is required. When rubbing or scouring, always move gently in the direction of the polish lines (grains). A Scotch-Brite™ general purpose pad may be used. **DO NOT USE STEEL WOOL.**

MAINTENANCE FOR LAMINATES

Laminate surfaces may be cleaned with warm water and mild soaps. Non-abrasive cleaners may also be used. Cleaning products containing bleaching agents should not be used. Large quantities of these agents or extended periods of time of exposure to them can cause discoloration.

CAUTION:

1. This equipment is designed and sold for commercial use only by personnel trained and experienced in its operation and is not sold for consumer use in and around the home nor for use directly by the general public in food service locations.
2. Do not immerse unit in water.
3. All repairs should be done by an authorized service center.
4. Unit should be turned off when not in use. It is recommended that unit be disconnected from power supply by removing plug from receptacle or shutting off power disconnect supply to the unit.

DOCKING DEVICE

The device comprises of two sub-assemblies: a male bullet catch and a female receiver with a locking plate.

1. Align the units so that the bullet catch and receivers line up.
2. Pull the lever and push the two units together so that the bullet catch is pushed all the way into the receiver.
3. Release the lever and the two units are now securely docked together.
4. To release the two units, pull the lever and slowly push the two units apart. Release the lever and now your units are separate.

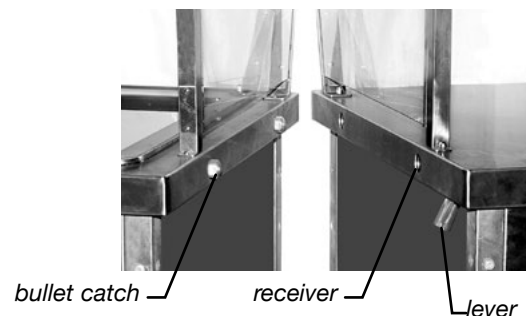

Director's Choice® Tray & Silverware Unit and Rack/Tray Dispensers

ASSEMBLY INSTRUCTIONS

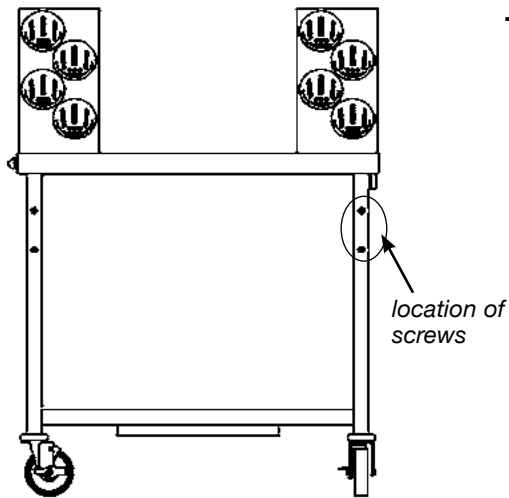

Tray Slides

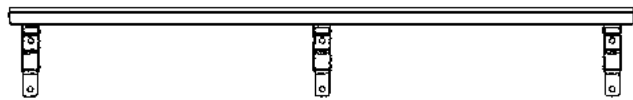

1. Remove screws from the front of the unit.
2. Hold tray slide up to unit and align the holes with the predrilled screw holes in the unit.
3. Tighten screws and make sure tray slide is securely mounted on unit.

Work Shelves

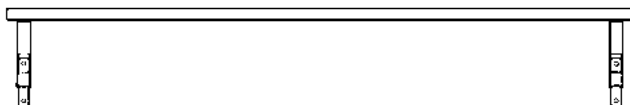
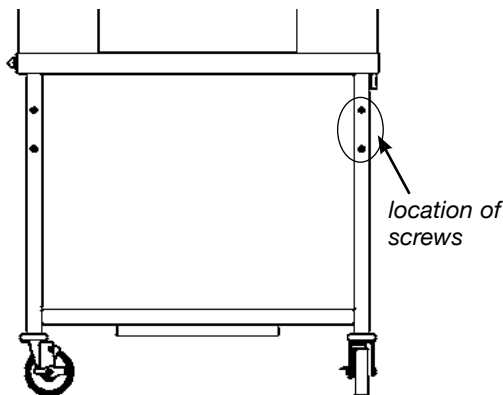

1. Remove screws from the rear of the unit.
2. Hold work shelf up to unit and align the holes with the predrilled screw holes in the unit.
3. Tighten screws and make sure work shelf is securely mounted on unit.



• 100 Industrial Boulevard, Clayton, Delaware 19938-8903 U.S.A.
• Phone: 302/653-3000 • 800/441-8440 • Fax: 302/653-2065
• www.eaglegrp.com • www.eaglemhc.com