

#YBM-MS4242-002-00 Microwave Shelving Unit

ASSEMBLY INSTRUCTIONS

CAUTION

INSPECT CONTENTS IMMEDIATELY AND FILE CLAIM WITH DELIVERING CARRIER FOR ANY DAMAGE.

SAVE YOUR BOX AND ALL PACKING MATERIALS.

YOU ARE RESPONSIBLE FOR DAMAGE TO YOUR UNIT IF RETURNED IMPROPERLY PACKED.

Parts List

#	qty	part #	description
#1	1	YJX2391-50	stainless steel shelf inlay
#2	1	2142V	wire overshelf
#3	2	OSP21-V	21" post
#4	1	YAX1330-2	tabletop
#5	2	3642V	wire shelf
#6	2	P55-V	55" post
#7	2	P34-V	34" post
#8	4	200024	foot slide
#9	2	303999	3/8-16 x 1 1/4" bolt
#10	2	300964	1/2" lock washer

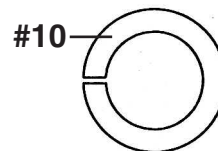
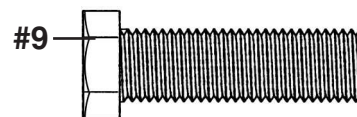

(actual size of hardware)

Required:

- rubber mallet
- piece of wood board
- 9/16" wrench

(continued on Page 2)

EG10045 Revised 12/05



• 100 Industrial Boulevard, Clayton, Delaware 19938-8903 U.S.A. • www.eaglegrp.com
• Phone: 302/653-3000 • (Foodservice) 800/441-8440 • (MHC/Retail) 800/637-5100
• Fax: 302/653-2065 or 302/653-3036

Eagle Foodservice Equipment, Eagle MHC, SpecFAB, and Retail Display are divisions of Eagle Group. ©2005 by the Eagle Group

#YBM-MS4242-002-00 Microwave Shelving Unit

ASSEMBLY INSTRUCTIONS

Step 1 - Assemble bottom undershelf to #8 groove on posts.

Snap split sleeves onto #8 groove on posts.

- The wider part of the taper goes toward the bottom.
- Make sure rib on split sleeve is seated into a groove on the post.

Note: The number covered by the split sleeve indicates approximate height of shelf.

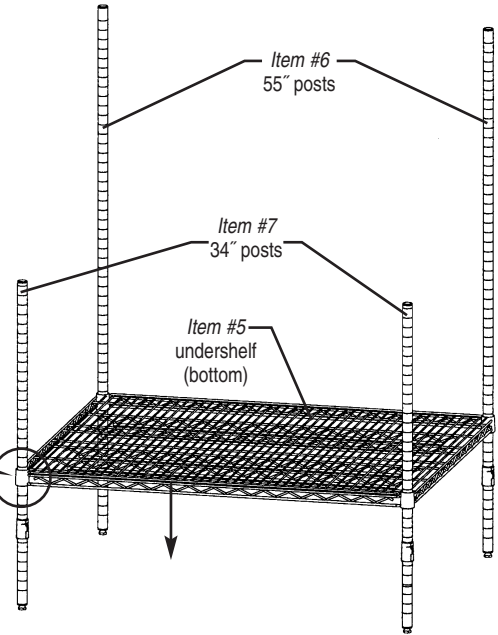
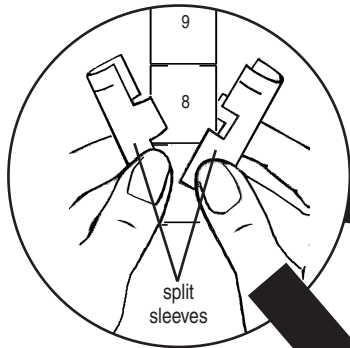

Slide bottom shelf collars over posts and down onto split sleeves.

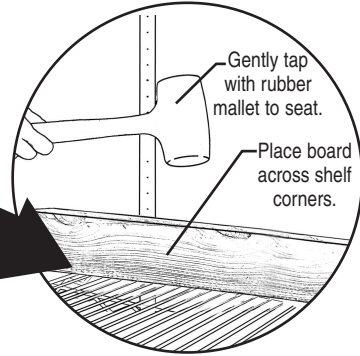
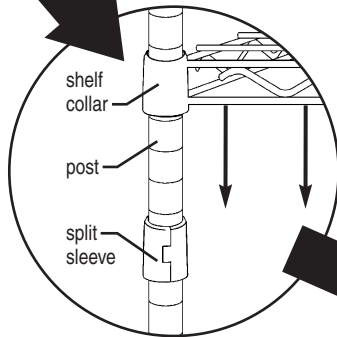

Step 2 - Assemble top undershelf to #21 groove on posts.

Repeat Step 1, attaching split sleeves onto #21 groove on posts.

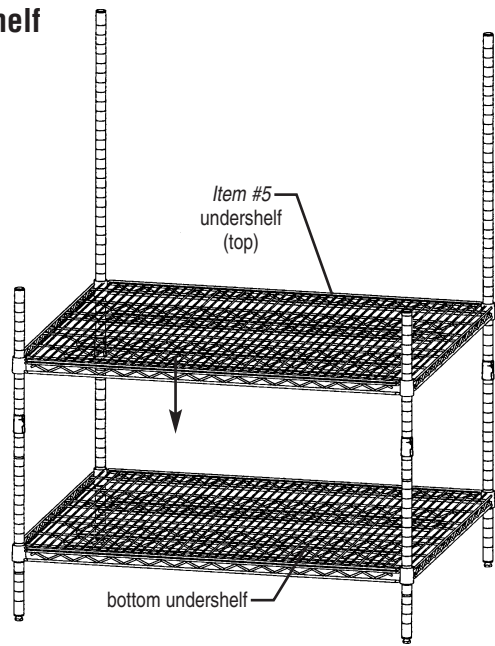

(continued on Page 3)

#YBM-MS4242-002-00 Microwave Shelving Unit

ASSEMBLY INSTRUCTIONS

Step 3 - Attach tabletop to unit.

Note: Make sure upturn is positioned at the side where the tallest posts are located.

Snap split sleeves onto top groove on front posts.

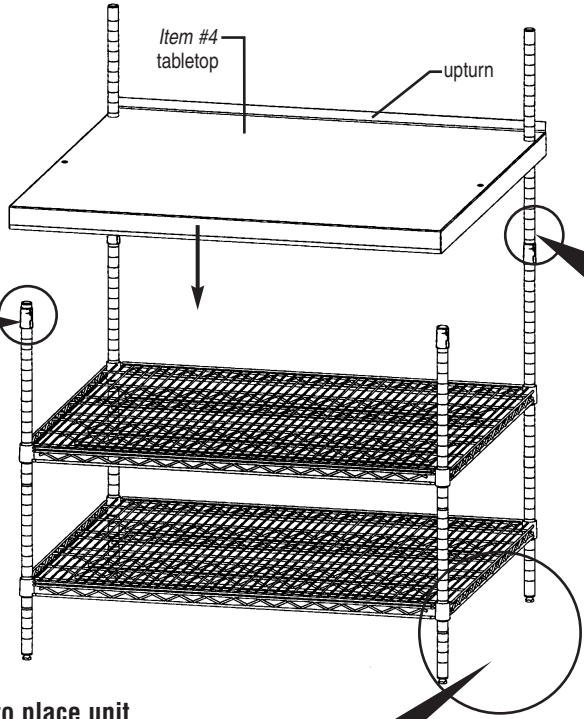
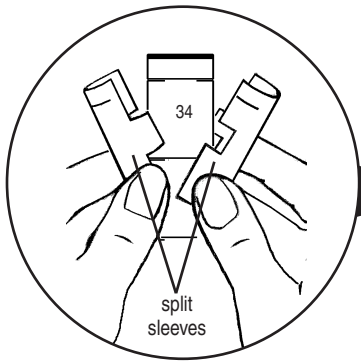

Snap split sleeves onto #34 groove on rear posts.

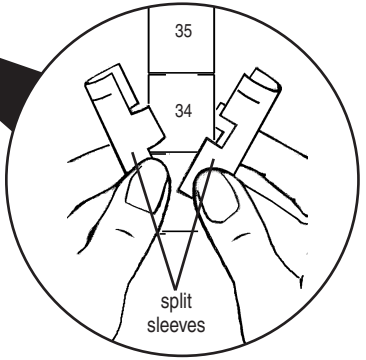

Please note: This is an ideal moment to place unit in desired location of room.

Step 4 - Level feet and place foot slides under posts.

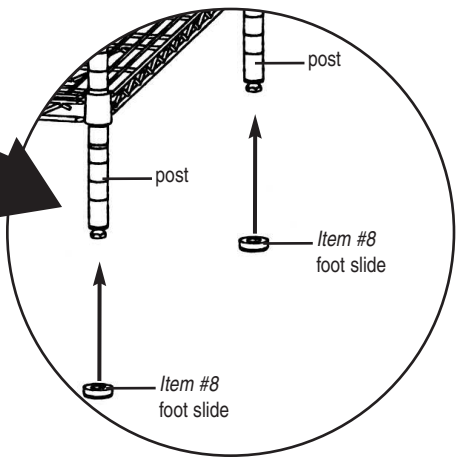
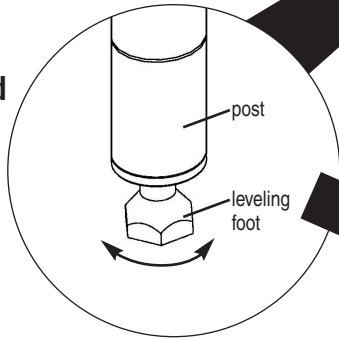

(continued on back page) 

#YBM-MS4242-002-00 Microwave Shelving Unit

ASSEMBLY INSTRUCTIONS

Step 5 - Attach 21" posts to tabletop with 9/16" wrench.

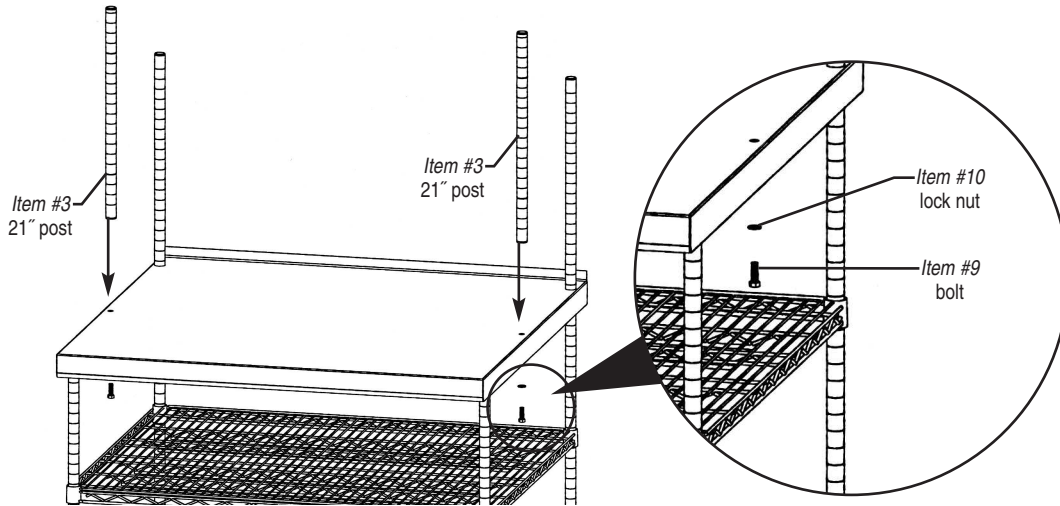

Step 6 - Assemble overshelf to unit.

Snap split sleeves onto top groove on posts.

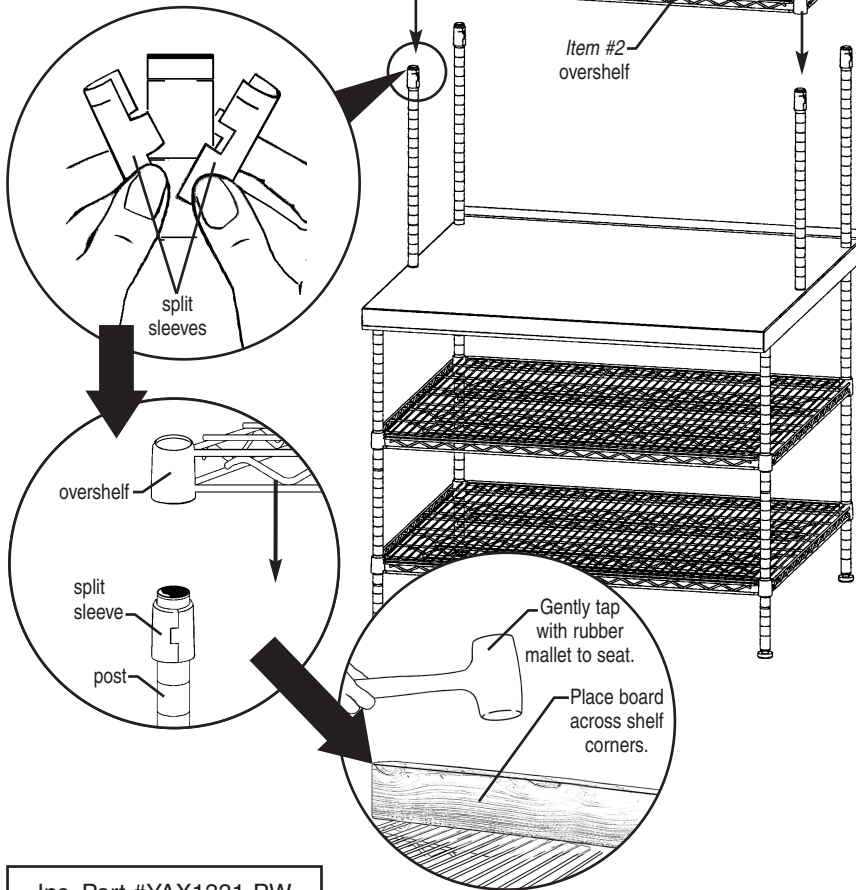

Step 7 - Place shelf inlay onto top of overshelf.

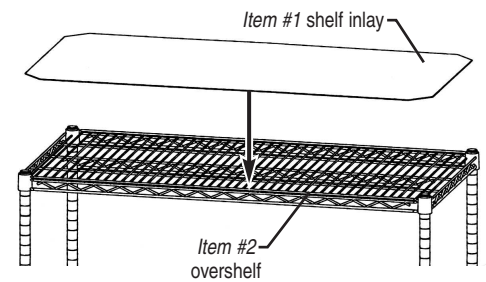

Assembly is complete.

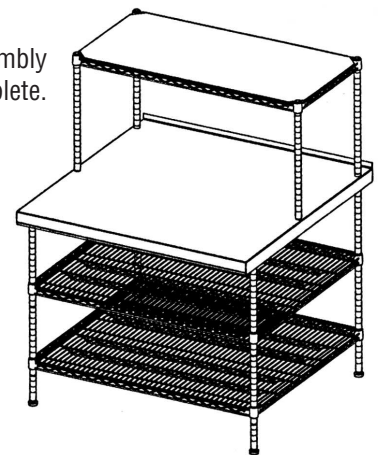

(End)

Ins. Part #YAX1331-PW



• 100 Industrial Boulevard, Clayton, Delaware 19938-8903 U.S.A. • www.eaglegrp.com
• Phone: 302/653-3000 • (Foodservice) 800/441-8440 • (MHC/Retail) 800/637-5100
• Fax: 302/653-2065 or 302/653-3036

Eagle Foodservice Equipment, Eagle MHC, SpecFAB, and Retail Display are divisions of Eagle Group. ©2005 by the Eagle Group