

Slicer Table

ASSEMBLY INSTRUCTIONS

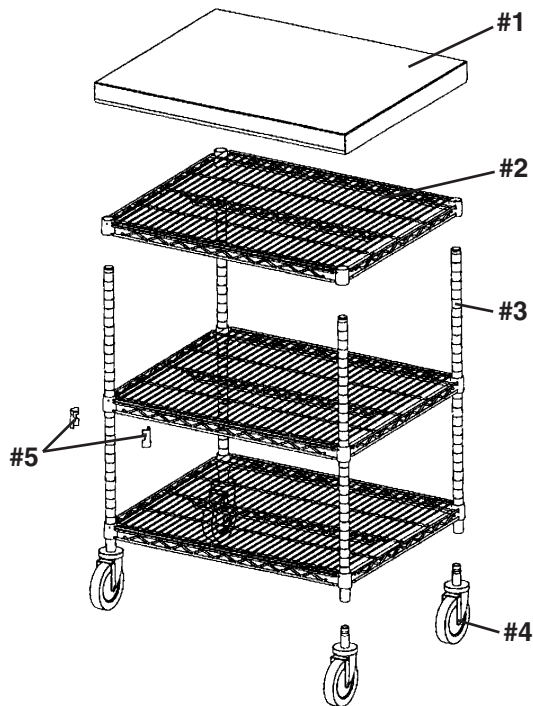

Parts List

<i>item</i>	<i>qty</i>	<i>part #</i>	<i>description</i>
#1	1	YJX2121-02	Tabletop, 25.5" x 30.5" with welded support channel, 16/304 finish
#2	3	2430V	Wire shelf, 24" x 30", QuadTruss®, Valu-Master® plating
#3	4	YJX2121-06	Post, 1" diameter x 31.125" with cap, Valu-Master® plating
#4	4	CSB5-300	Stem caster, 5" diameter x 1.25" wide resilient tread with brake, zinc
#5	3	A200816	Split sleeves for 1" diameter post, black plastic, bag of four, one bag per shelf

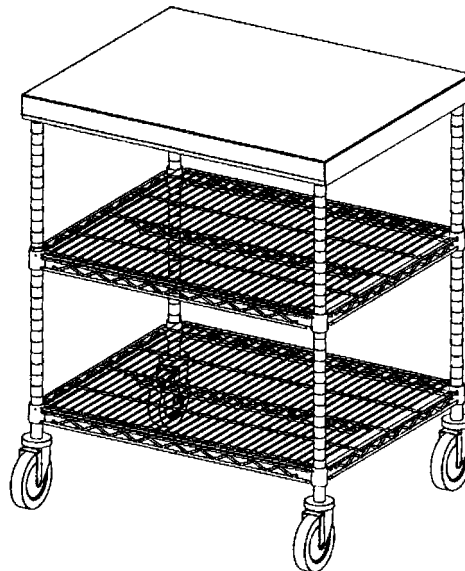

fully assembled slicer table

Please review enclosed instructions #A200815 before you begin.