

QuadPLUS® Grid Panel Clamps

ASSEMBLY INSTRUCTIONS

CAUTION

INSPECT CONTENTS IMMEDIATELY AND FILE CLAIM WITH DELIVERING CARRIER FOR ANY DAMAGE.
SAVE YOUR BOX AND ALL PACKING MATERIALS.
YOU ARE RESPONSIBLE FOR DAMAGE TO YOUR UNIT IF RETURNED IMPROPERLY PACKED.

BEFORE ASSEMBLY, PLEASE READ:

- Determine locations of clamps BEFORE assembling shelf unit.
- Clamp collars can be installed either before or after shelves, depending on preference.
- Installation must be bottom-to-top. Install bottommost set of collars first, making sure all clamp collars are the same height along posts.
- Make sure threads are facing outward.

locations of panel clamp collars

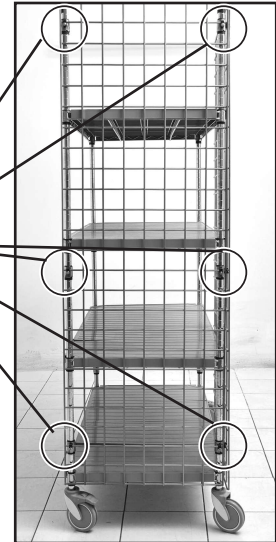

Step 1

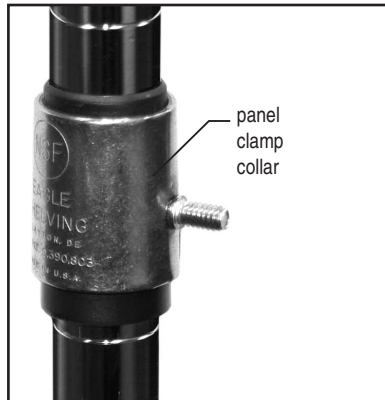

Step 2

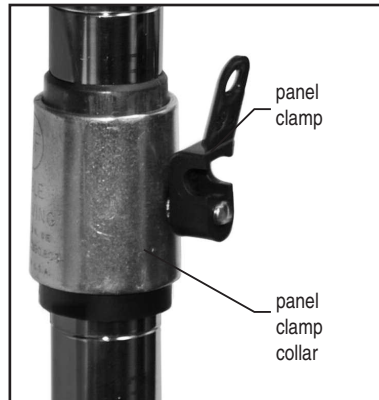

Step 3

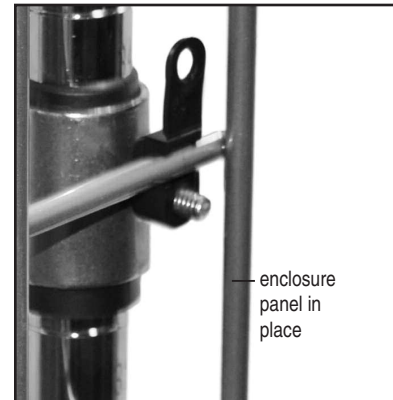

Step 4

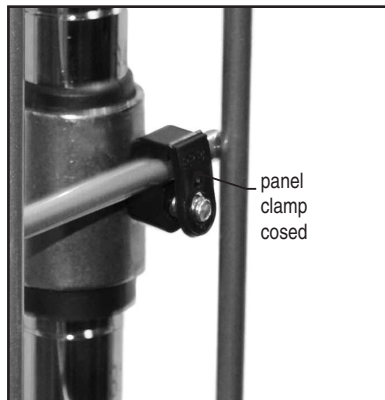

Step 5

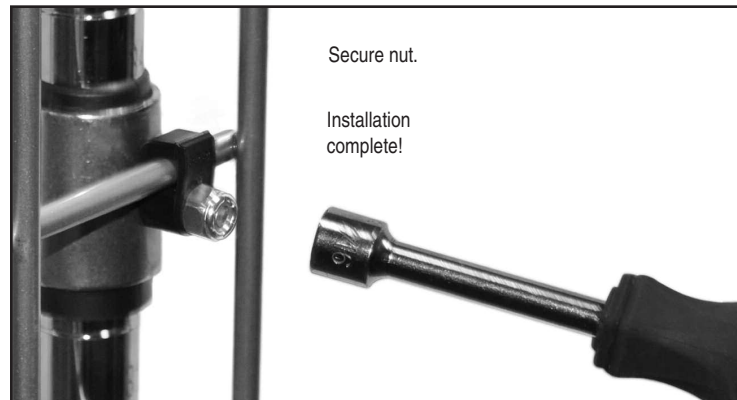

(End)

Revised 10/15