



Profit from the Eagle Advantage®

Specification Sheet

Short Form Specifications

Eagle worktables, Budget series, model _____.
 Top constructed of heavy gauge type 430 stainless steel with 1½" roll on front, 1½" rear upturn, and sides turned down 90°. Undershelf is adjustable and constructed of heavy gauge type 430 stainless steel with marine edge. Top reinforced with hat channels and sound deadened. Constructed with uni-lok® patented gusset system with the gussets recessed to reduce lateral movement. Legs are 1½" O.D. stainless steel, with galvanized gussets and 1" stainless steel adjustable bullet feet.



worktable with upturn and adjustable undershelf

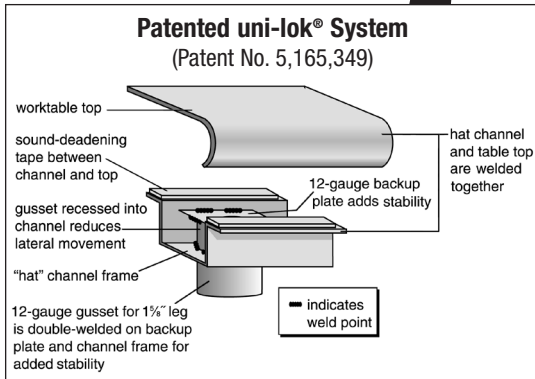

Item No.: _____
 Project No.: _____
 S.I.S. No.: _____

Worktables with Rear Upturn and Stainless Steel Base with Adjustable Undershelf — Budget Series

MODELS:

- | | | | |
|-----------------------------------|------------------------------------|------------------------------------|------------------------------------|
| <input type="checkbox"/> UT2424SB | <input type="checkbox"/> UT24108SB | <input type="checkbox"/> UT3072SB | <input type="checkbox"/> UT3660SB |
| <input type="checkbox"/> UT2430SB | <input type="checkbox"/> UT24120SB | <input type="checkbox"/> UT3084SB | <input type="checkbox"/> UT3672SB |
| <input type="checkbox"/> UT2436SB | <input type="checkbox"/> UT24132SB | <input type="checkbox"/> UT3096SB | <input type="checkbox"/> UT3684SB |
| <input type="checkbox"/> UT2448SB | <input type="checkbox"/> UT24144SB | <input type="checkbox"/> UT30108SB | <input type="checkbox"/> UT3696SB |
| <input type="checkbox"/> UT2460SB | <input type="checkbox"/> UT3030SB | <input type="checkbox"/> UT30120SB | <input type="checkbox"/> UT36108SB |
| <input type="checkbox"/> UT2472SB | <input type="checkbox"/> UT3036SB | <input type="checkbox"/> UT30132SB | <input type="checkbox"/> UT36120SB |
| <input type="checkbox"/> UT2484SB | <input type="checkbox"/> UT3048SB | <input type="checkbox"/> UT30144SB | <input type="checkbox"/> UT36132SB |
| <input type="checkbox"/> UT2496SB | <input type="checkbox"/> UT3060SB | <input type="checkbox"/> UT3648SB | <input type="checkbox"/> UT36144SB |

Tabletop

- Patented uni-lok® gusset system (patent #5,165,349): gussets are recessed into hat channel, reducing lateral movement.
- Top reinforced with welded-on hat channel.
- Sound-deadened between top and channels.
- 1½" (38mm) 90° rear upturn with radius at intersection.
- 1½" (41mm)-diameter 180° rolled edge on front. Ends are turned down 90° providing for flush installations when required.
- Heavy gauge type 430 polished stainless steel.

Adjustable Undershelf

- Heavy gauge stainless steel.
- Gusset welded on each corner.
- Heavy duty marine edge.

Legs—1½" (41mm)-diameter

- Units 96" to 120" (2438 to 3048mm) long come with six legs; Units 132" and 144" (3353 and 3658mm) come with eight legs.
- Heavy gauge stainless steel.
- 1" (25mm) adjustable stainless steel feet.

Options / Accessories

- | | |
|--|--|
| <input type="checkbox"/> Drawer | <input type="checkbox"/> Duplex receptacles |
| <input type="checkbox"/> Lock | <input type="checkbox"/> Pot rack |
| <input type="checkbox"/> Casters | <input type="checkbox"/> Sink |
| <input type="checkbox"/> Overshelves | <input type="checkbox"/> Additional undershelf |
| <input type="checkbox"/> Knockdown Welded Base (see back page) | <input type="checkbox"/> Stabilizer Bar (for 30"- and 36"-wide tables) |

Certifications / Approvals



EAGLE GROUP

100 Industrial Boulevard, Clayton, DE 19938-8903 USA
 Phone: 302-653-3000 • 800-441-8440 • Fax: 302-653-2065
 www.eaglegrp.com
 www.eaglehmc.com

For custom configuration or fabrication needs, contact our SpecFAB® Division.
 Phone: 302-653-3000 • Fax: 302-653-2065 • e-mail: quotes@eaglegrp.com

EG10.48A Rev. 08/24

Spec sheets available for viewing, printing or downloading from our online literature library at our websites



Item No.: _____
 Project No.: _____
 S.I.S. No.: _____

Worktables with Rear Upturn and Stainless Steel Base with Adjustable Undershelf—Budget Series

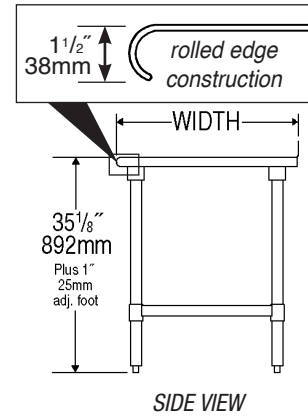
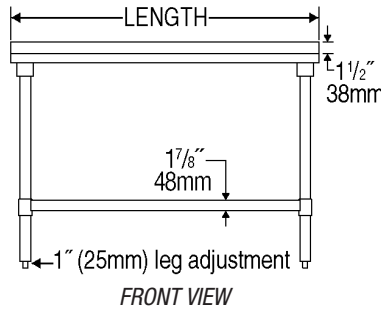
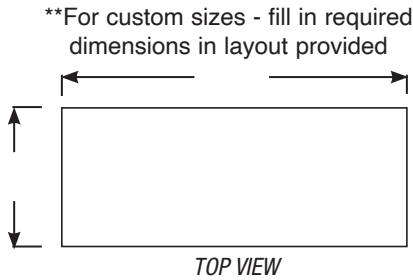

model #	# of legs	width		length		weight	
		in.	mm	in.	mm	lbs.	kg
UT2424SB	4	24"	610	24"	610	44	20.0
UT2430SB	4	24"	610	30"	762	50	22.7
UT2436SB	4	24"	610	36"	914	55	25.0
UT2448SB	4	24"	610	48"	1219	67	30.4
UT2460SB	4	24"	610	60"	1524	71	32.2
UT2472SB	4	24"	610	72"	1829	90	40.8
UT2484SB	4	24"	610	84"	2134	98	44.5
UT2496SB	6	24"	610	96"	2438	114	51.7
UT24108SB	6	24"	610	108"	2743	131	59.4
UT24120SB	6	24"	610	120"	3048	148	67.1
UT24132SB	8	24"	610	132"	3353	177	80.3
UT24144SB	8	24"	610	144"	3658	220	99.8
UT3030SB	4	30"	762	30"	762	54	24.5
UT3036SB	4	30"	762	36"	914	64	29.0
UT3048SB	4	30"	762	48"	1219	74	33.6
UT3060SB	4	30"	762	60"	1524	87	39.5
UT3072SB	4	30"	762	72"	1829	94	42.6
UT3084SB	4	30"	762	84"	2134	105	47.6
UT3096SB	6	30"	762	96"	2438	126	57.2
UT30108SB	6	30"	762	108"	2743	199	90.3
UT30120SB	6	30"	762	120"	3048	205	93.0
UT30132SB	8	30"	762	132"	3353	211	95.7
UT30144SB	8	30"	762	144"	3658	218	98.9
UT3648SB	4	36"	914	48"	1219	83	37.7
UT3660SB	4	36"	914	60"	1524	108	49.0
UT3672SB	4	36"	914	72"	1829	114	51.7
UT3684SB	4	36"	914	84"	2134	183	83.0
UT3696SB	6	36"	914	96"	2438	205	93.0
UT36108SB	6	36"	914	108"	2743	206	93.4
UT36120SB	6	36"	914	120"	3048	210	95.3
UT36132SB	8	36"	914	132"	3353	228	103.4
UT36144SB	8	36"	914	144"	3658	261	118.4

NEW Option for Worktables with Stainless Steel Base: Knockdown Welded Base

PATENT PENDING

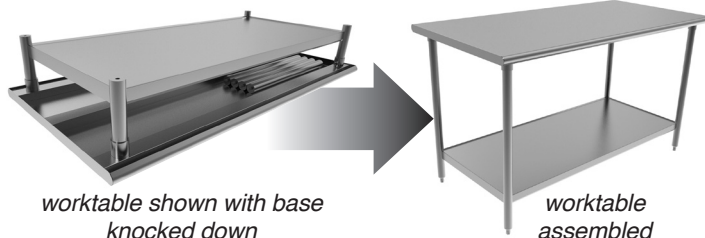

worktable shown with base knocked down

worktable assembled

- Precision machined stainless steel threaded inserts pressed into 16 gauge 1 5/8"-diameter leg sections for knockdown construction
- Marine edge stainless steel undershelf welded to lower leg sections

Add suffix "**-KDWB**" to worktable model number (ex: UT2436SB-**KDWB**). See EG8217 for more info.

EAGLE GROUP
 100 Industrial Boulevard, Clayton, DE 19938-8903 USA
 Phone: 302-653-3000 or 800-441-8440 • Fax: 302-653-2065
 www.eaglegrp.com • www.eaglehmc.com

Printed in U.S.A.
 ©2024 by Eagle Group

Rev. 08/24

Spec sheets available for viewing, printing or downloading from our online literature library at our websites

Although every attempt has been made to ensure the accuracy of the information provided, we cannot be held responsible for typographical or printing errors. Information and specifications are subject to change without notice. Please confirm at time of order.