



Profit from the Eagle Advantage®

Specification Sheet

Short Form Specifications

Eagle worktables, Spec-Master® Marine series, model _____ . Top constructed of 14 gauge 300 series stainless steel, with 2 1/8" marine counter style edging on all four sides. Undershelf is adjustable and constructed of 18 gauge 300 series stainless steel, with marine edge. Top reinforced with stainless steel hat channels and sound deadened. Constructed with uni-lok® patented gusset system with the gussets recessed into the hat channels to reduce lateral movement. Legs are 1 1/2" O.D., stainless steel, with stainless steel gussets and 1" stainless steel adjustable bullet feet.

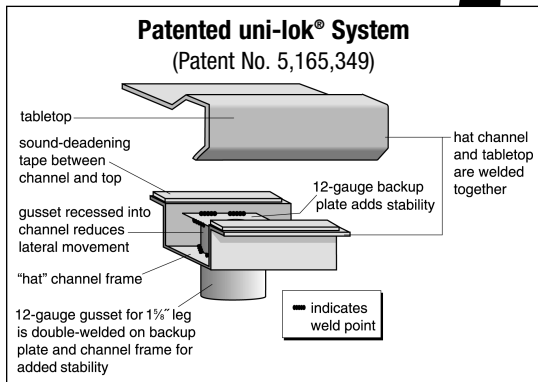

Item No.: _____
 Project No.: _____
 S.I.S. No.: _____

Worktables with Flat Top and Stainless Steel Base with Undershelf —Spec-Master® Marine Series

MODELS:

- | | | | |
|------------------------------------|------------------------------------|------------------------------------|------------------------------------|
| <input type="checkbox"/> T2424SEM | <input type="checkbox"/> T24144SEM | <input type="checkbox"/> T30132SEM | <input type="checkbox"/> T36144SEM |
| <input type="checkbox"/> T2430SEM | <input type="checkbox"/> T3030SEM | <input type="checkbox"/> T30144SEM | <input type="checkbox"/> T4848SEM |
| <input type="checkbox"/> T2436SEM | <input type="checkbox"/> T3036SEM | <input type="checkbox"/> T3648SEM | <input type="checkbox"/> T4860SEM |
| <input type="checkbox"/> T2448SEM | <input type="checkbox"/> T3048SEM | <input type="checkbox"/> T3660SEM | <input type="checkbox"/> T4872SEM |
| <input type="checkbox"/> T2460SEM | <input type="checkbox"/> T3060SEM | <input type="checkbox"/> T3672SEM | <input type="checkbox"/> T4884SEM |
| <input type="checkbox"/> T2472SEM | <input type="checkbox"/> T3072SEM | <input type="checkbox"/> T3684SEM | <input type="checkbox"/> T4896SEM |
| <input type="checkbox"/> T2484SEM | <input type="checkbox"/> T3084SEM | <input type="checkbox"/> T3696SEM | <input type="checkbox"/> T48108SEM |
| <input type="checkbox"/> T2496SEM | <input type="checkbox"/> T3096SEM | <input type="checkbox"/> T36108SEM | <input type="checkbox"/> T48120SEM |
| <input type="checkbox"/> T24108SEM | <input type="checkbox"/> T30108SEM | <input type="checkbox"/> T36120SEM | <input type="checkbox"/> T48132SEM |
| <input type="checkbox"/> T24120SEM | <input type="checkbox"/> T30120SEM | <input type="checkbox"/> T36132SEM | <input type="checkbox"/> T48144SEM |
| <input type="checkbox"/> T24132SEM | | | |

Tabletop

- Patented uni-lok® gusset system (patent #5,165,349): gussets are recessed into hat channel, reducing lateral movement.
- Top reinforced with welded-on hat channel.
- Sound-deadened between top and channels.
- Marine counter edge on all four sides.
- 14 gauge 300 series polished stainless steel.

Adjustable Undershelf

- 18 gauge 300 series stainless steel.
- Gusset welded to each corner.
- Heavy duty marine edge design.

Legs—1 1/2" (41mm)-diameter

- 24" to 36" (610 to 914mm)-wide units that are 96" (2438mm) and longer come with six legs or more. 48" (1219mm)-wide units that are 72" (1829mm) and longer come with six legs or more.
- Heavy gauge stainless steel.
- 1" (25mm) adjustable stainless steel feet.

Options / Accessories

- | | |
|----------------------------------------------------------------|------------------------------------------------------------------------|
| <input type="checkbox"/> Drawer | <input type="checkbox"/> Duplex receptacles |
| <input type="checkbox"/> Lock | <input type="checkbox"/> Pot rack |
| <input type="checkbox"/> Casters | <input type="checkbox"/> Sink |
| <input type="checkbox"/> Overshelves | <input type="checkbox"/> Additional undershelf |
| <input type="checkbox"/> Knockdown Welded Base (see back page) | <input type="checkbox"/> Stabilizer Bar (for 30"- and 36"-wide tables) |

EAGLE GROUP

100 Industrial Boulevard, Clayton, DE 19938-8903 USA
 Phone: 302-653-3000 • 800-441-8440 • Fax: 302-653-2065
www.eaglegrp.com
www.eaglemhc.com

For custom configuration or fabrication needs, contact our SpecFAB® Division.
 Phone: 302-653-3000 • Fax: 302-653-2065 • e-mail: quotes@eaglegrp.com



EG10.41D Rev. 06/24

Spec sheets available for viewing, printing or downloading from our online literature library at our websites



Profit from the Eagle Advantage®

Item No.: _____
 Project No.: _____
 S.I.S. No.: _____

Worktables with Flat Top and Stainless Steel Base with Undershelf—Spec-Master® Marine Series

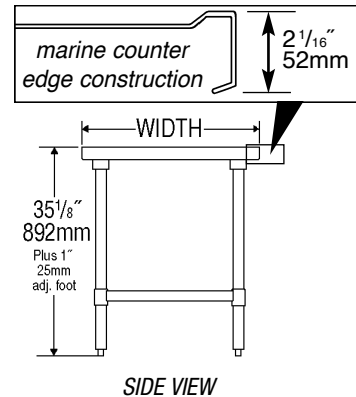
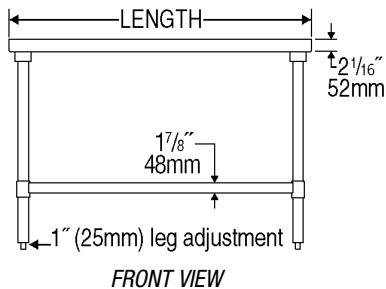
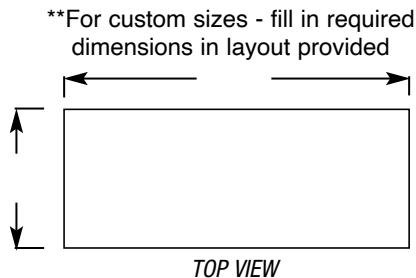

model #	# of legs	width		length		weight	
		in.	mm	in.	mm	lbs.	kg
T2424SEM	4	24"	610	24"	610	46	20.9
T2430SEM	4	24"	610	30"	762	50	22.7
T2436SEM	4	24"	610	36"	914	55	24.9
T2448SEM	4	24"	610	48"	1219	67	30.4
T2460SEM	4	24"	610	60"	1524	78	35.4
T2472SEM	4	24"	610	72"	1829	90	40.8
T2484SEM	4	24"	610	84"	2134	103	46.3
T2496SEM	6	24"	610	96"	2438	125	56.7
T24108SEM	6	24"	610	108"	2743	144	65.3
T24120SEM	6	24"	610	120"	3048	163	73.9
T24132SEM	8	24"	610	132"	3353	186	84.4
T24144SEM	8	24"	610	144"	3658	200	90.7
T3030SEM	4	30"	762	30"	762	54	24.5
T3036SEM	4	30"	762	36"	914	57	25.9
T3048SEM	4	30"	762	48"	1219	75	34.0
T3060SEM	4	30"	762	60"	1524	87	39.5
T3072SEM	4	30"	762	72"	1829	101	45.8
T3084SEM	4	30"	762	84"	2134	116	52.6
T3096SEM	6	30"	762	96"	2438	139	63.1
T30108SEM	6	30"	762	108"	2743	161	73.0
T30120SEM	6	30"	762	120"	3048	182	82.6
T30132SEM	8	30"	762	132"	3353	204	92.5
T30144SEM	8	30"	762	144"	3658	224	101.6
T3648SEM	4	36"	914	48"	1219	83	37.6
T3660SEM	4	36"	914	60"	1524	97	44.0
T3672SEM	4	36"	914	72"	1829	114	51.7
T3684SEM	4	36"	914	84"	2134	132	59.9
T3696SEM	6	36"	914	96"	2438	153	69.4
T36108SEM	6	36"	914	108"	2743	180	81.6
T36120SEM	6	36"	914	120"	3048	207	93.9
T36132SEM	8	36"	914	132"	3353	234	106.1
T36144SEM	8	36"	914	144"	3658	261	118.4
T4848SEM	4	48"	1219	48"	1219	136	61.7
T4860SEM	4	48"	1219	60"	1524	161	73.0
T4872SEM	6	48"	1219	72"	1829	188	85.3
T4884SEM	8	48"	1219	84"	2134	217	98.4
T4896SEM	8	48"	1219	96"	2438	265	120.2
T48108SEM	8	48"	1219	108"	2743	306	138.8
T48120SEM	8	48"	1219	120"	3048	348	157.9
T48132SEM	8	48"	1219	132"	3353	388	176.0
T48144SEM	8	48"	1219	144"	3658	430	195.0

NEW Option for Worktables with Stainless Steel Base: Knockdown Welded Base

PATENT PENDING

worktable with base knocked down

worktable assembled

- Precision machined stainless steel threaded inserts pressed into 16 gauge 1 7/8"-diameter leg sections for knockdown construction
- Marine edge stainless steel undershelf welded to lower leg sections

Add suffix "**-KDWB**" to worktable model number (ex: T3060SEM-KDWB). See EG8217 for more info.

EAGLE GROUP
 100 Industrial Boulevard, Clayton, DE 19938-8903 USA
 Phone: 302-653-3000 or 800-441-8440 • Fax: 302-653-2065
 www.eaglegrp.com • www.eaglehmc.com

Printed in U.S.A.
 ©2024 by Eagle Group
 Rev. 06/24

Spec sheets available for viewing, printing or downloading from our online literature library at our websites

Although every attempt has been made to ensure the accuracy of the information provided, we cannot be held responsible for typographical or printing errors. Information and specifications are subject to change without notice. Please confirm at time of order.