



Profit from the Eagle Advantage®

Specification Sheet

Short Form Specifications

Eagle worktables, Deluxe series, model _____.
 Top constructed of 16 gauge 300 series stainless steel with 1½" roll on front and rear, and sides turned down 90°. Undershef is adjustable and constructed of heavy gauge type 430 stainless steel with marine edge. Top reinforced with hat channels and sound deadened. Constructed with uni-lok® patented gusset system with the gussets recessed into the hat channels to reduce lateral movement. Legs are 1½" O.D., stainless steel, with galvanized gussets and 1" stainless steel adjustable bullet feet.



worktable with flat top and undershef

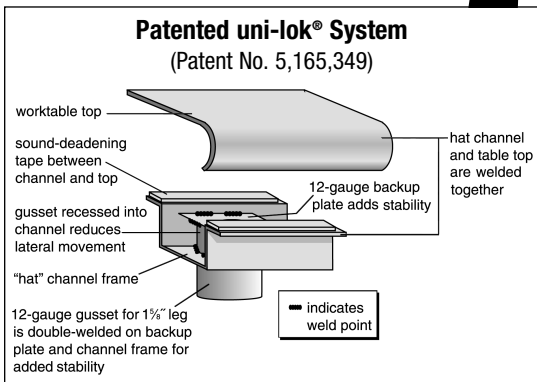

Patented uni-lok® System (Patent No. 5,165,349)

Item No.: _____
 Project No.: _____
 S.I.S. No.: _____

Worktables with Flat Top and Stainless Steel Base with Undershef—Deluxe Series

MODELS:

- | | | | |
|-----------------------------------|------------------------------------|------------------------------------|------------------------------------|
| <input type="checkbox"/> T2424SEB | <input type="checkbox"/> T24108SEB | <input type="checkbox"/> T3072SEB | <input type="checkbox"/> T3660SEB |
| <input type="checkbox"/> T2430SEB | <input type="checkbox"/> T24120SEB | <input type="checkbox"/> T3084SEB | <input type="checkbox"/> T3672SEB |
| <input type="checkbox"/> T2436SEB | <input type="checkbox"/> T24132SEB | <input type="checkbox"/> T3096SEB | <input type="checkbox"/> T3684SEB |
| <input type="checkbox"/> T2448SEB | <input type="checkbox"/> T24144SEB | <input type="checkbox"/> T30108SEB | <input type="checkbox"/> T3696SEB |
| <input type="checkbox"/> T2460SEB | <input type="checkbox"/> T3030SEB | <input type="checkbox"/> T30120SEB | <input type="checkbox"/> T36108SEB |
| <input type="checkbox"/> T2472SEB | <input type="checkbox"/> T3036SEB | <input type="checkbox"/> T30132SEB | <input type="checkbox"/> T36120SEB |
| <input type="checkbox"/> T2484SEB | <input type="checkbox"/> T3048SEB | <input type="checkbox"/> T30144SEB | <input type="checkbox"/> T36132SEB |
| <input type="checkbox"/> T2496SEB | <input type="checkbox"/> T3060SEB | <input type="checkbox"/> T3648SEB | <input type="checkbox"/> T36144SEB |

Tabletop

- Patented uni-lok® gusset system (patent #5,165,349): gussets are recessed into hat channel, reducing lateral movement.
- Top reinforced with welded-on hat channel.
- Sound-deadened between top and channels.
- 1½" (38mm)-diameter 180° rolled edges on front and rear. Ends are turned down 90° providing for flush installations when required.
- 16 gauge 300 series polished stainless steel.

Adjustable Undershef

- Heavy gauge stainless steel.
- Gusset welded to each corner.
- Heavy duty marine edge design.

Legs—1½" (41mm)-diameter

- Tables 96" (2438mm) and longer come with six legs or more.
- Heavy gauge stainless steel.
- 1" (25mm) adjustable stainless steel feet.

Options / Accessories

- | | |
|--|--|
| <input type="checkbox"/> Drawer | <input type="checkbox"/> Duplex receptacles |
| <input type="checkbox"/> Lock | <input type="checkbox"/> Pot rack |
| <input type="checkbox"/> Casters | <input type="checkbox"/> Sink |
| <input type="checkbox"/> Overshelves | <input type="checkbox"/> Additional undershef |
| <input type="checkbox"/> Knockdown Welded Base (see back page) | <input type="checkbox"/> Stabilizer Bar (for 30"- and 36"-wide tables) |

EAGLE GROUP

100 Industrial Boulevard, Clayton, DE 19938-8903 USA
 Phone: 302-653-3000 • 800-441-8440 • Fax: 302-653-2065
 www.eaglegrp.com
 www.eaglemhc.com

For custom configuration or fabrication needs, contact our SpecFAB® Division.
 Phone: 302-653-3000 • Fax: 302-653-2065 • e-mail: quotes@eaglegrp.com

Certifications / Approvals



AutoQuotes



EG10.41B Rev. 06/24

Spec sheets available for viewing, printing or downloading from our online literature library at our websites



Item No.: _____
 Project No.: _____
 S.I.S. No.: _____

Worktables with Flat Top and Stainless Steel Base with Undershelf—Deluxe Series

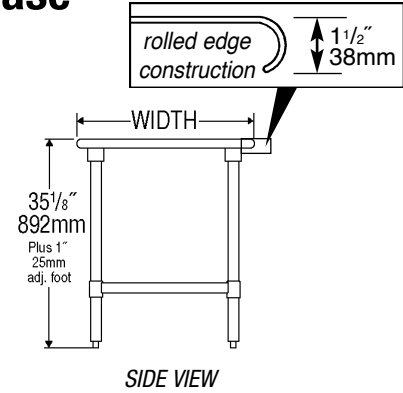
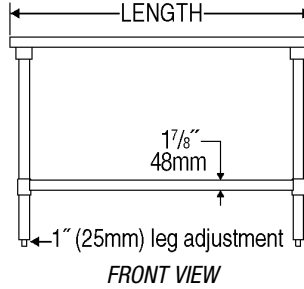
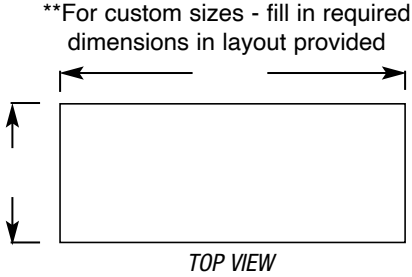

model #	# of legs	width		length		weight	
		in.	mm	in.	mm	lbs.	kg
T2424SEB	4	24"	610	24"	610	42	19.0
T2430SEB	4	24"	610	30"	762	45	20.4
T2436SEB	4	24"	610	36"	914	50	22.7
T2448SEB	4	24"	610	48"	1219	61	27.7
T2460SEB	4	24"	610	60"	1524	71	32.2
T2472SEB	4	24"	610	72"	1829	82	37.2
T2484SEB	4	24"	610	84"	2134	94	42.6
T2496SEB	6	24"	610	96"	2438	114	51.7
T24108SEB	6	24"	610	108"	2743	131	59.4
T24120SEB	6	24"	610	120"	3048	148	67.1
T24132SEB	8	24"	610	132"	3353	165	74.8
T24144SEB	8	24"	610	144"	3658	182	82.6
T3030SEB	4	30"	762	30"	762	49	22.0
T3036SEB	4	30"	762	36"	914	52	23.6
T3048SEB	4	30"	762	48"	1219	68	30.1
T3060SEB	4	30"	762	60"	1524	79	35.8
T3072SEB	4	30"	762	72"	1829	92	41.7
T3084SEB	4	30"	762	84"	2134	105	47.6
T3096SEB	6	30"	762	96"	2438	126	57.2
T30108SEB	6	30"	762	108"	2743	146	66.2
T30120SEB	6	30"	762	120"	3048	165	74.8
T30132SEB	8	30"	762	132"	3353	185	84.0
T30144SEB	8	30"	762	144"	3658	204	92.5
T3648SEB	4	36"	914	48"	1219	75	34.0
T3660SEB	4	36"	914	60"	1524	88	40.0
T3672SEB	4	36"	914	72"	1829	104	47.2
T3684SEB	4	36"	914	84"	2134	120	54.4
T3696SEB	6	36"	914	96"	2438	139	63.1
T36108SEB	6	36"	914	108"	2743	164	74.4
T36120SEB	6	36"	914	120"	3048	188	85.3
T36132SEB	8	36"	914	132"	3353	213	96.6
T36144SEB	8	36"	914	144"	3658	237	107.5

NEW Option for Worktables with Stainless Steel Base: Knockdown Welded Base

PATENT PENDING

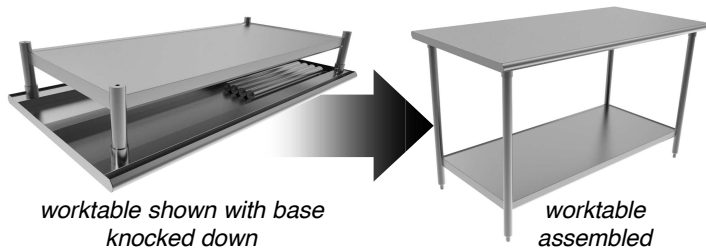

- Precision machined stainless steel threaded inserts pressed into 16 gauge 1 1/8"-diameter leg sections for knockdown construction
- Marine edge stainless steel undershelf welded to lower leg sections

Add suffix "-KDWB" to worktable model number (ex: T2436SEB-KDWB). See EG8217 for more info.

EAGLE GROUP
 100 Industrial Boulevard, Clayton, DE 19938-8903 USA
 Phone: 302-653-3000 or 800-441-8440 • Fax: 302-653-2065
 www.eaglegrp.com • www.eaglehmc.com

Printed in U.S.A.
 ©2024 by Eagle Group

Rev. 06/24

Spec sheets available for viewing, printing or downloading from our online literature library at our websites

Although every attempt has been made to ensure the accuracy of the information provided, we cannot be held responsible for typographical or printing errors. Information and specifications are subject to change without notice. Please confirm at time of order.