



Profit from the Eagle Advantage®

# Specification Sheet

## Short Form Specifications

Eagle worktables, Deluxe series, model \_\_\_\_\_.  
Top constructed of 16 gauge 300 series stainless steel with 1½" roll on front and rear, and sides turned down 90°. Undershef is adjustable and constructed of heavy gauge type 430 stainless steel with marine edge. Top reinforced with hat channels and sound deadened. Constructed with uni-lok® patented gusset system with the gussets recessed into the hat channels to reduce lateral movement. Legs are 1½" O.D., stainless steel, with galvanized gussets and 1" stainless steel adjustable bullet feet.



worktable with flat top and undershef

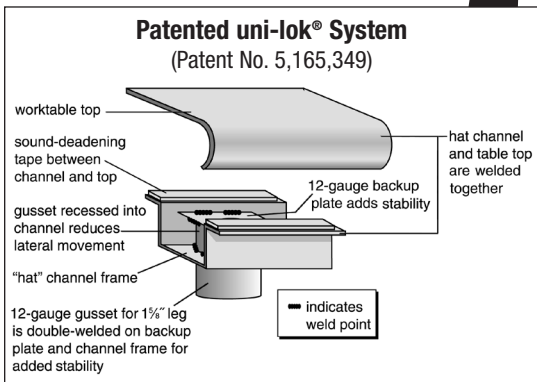

Item No.: \_\_\_\_\_  
Project No.: \_\_\_\_\_  
S.I.S. No.: \_\_\_\_\_

## Worktables with Flat Top and Stainless Steel Base with Undershef—Deluxe Series

### MODELS:

- |                                   |                                    |                                    |                                    |
|-----------------------------------|------------------------------------|------------------------------------|------------------------------------|
| <input type="checkbox"/> T2424SEB | <input type="checkbox"/> T24108SEB | <input type="checkbox"/> T3072SEB  | <input type="checkbox"/> T3660SEB  |
| <input type="checkbox"/> T2430SEB | <input type="checkbox"/> T24120SEB | <input type="checkbox"/> T3084SEB  | <input type="checkbox"/> T3672SEB  |
| <input type="checkbox"/> T2436SEB | <input type="checkbox"/> T24132SEB | <input type="checkbox"/> T3096SEB  | <input type="checkbox"/> T3684SEB  |
| <input type="checkbox"/> T2448SEB | <input type="checkbox"/> T24144SEB | <input type="checkbox"/> T30108SEB | <input type="checkbox"/> T3696SEB  |
| <input type="checkbox"/> T2460SEB | <input type="checkbox"/> T3030SEB  | <input type="checkbox"/> T30120SEB | <input type="checkbox"/> T36108SEB |
| <input type="checkbox"/> T2472SEB | <input type="checkbox"/> T3036SEB  | <input type="checkbox"/> T30132SEB | <input type="checkbox"/> T36120SEB |
| <input type="checkbox"/> T2484SEB | <input type="checkbox"/> T3048SEB  | <input type="checkbox"/> T30144SEB | <input type="checkbox"/> T36132SEB |
| <input type="checkbox"/> T2496SEB | <input type="checkbox"/> T3060SEB  | <input type="checkbox"/> T3648SEB  | <input type="checkbox"/> T36144SEB |

### Tabletop

- Patented uni-lok® gusset system (patent #5,165,349): gussets are recessed into hat channel, reducing lateral movement.
- Top reinforced with welded-on hat channel.
- Sound-deadened between top and channels.
- 1½" (38mm)-diameter 180° rolled edges on front and rear. Ends are turned down 90° providing for flush installations when required.
- 16 gauge 300 series polished stainless steel.

### Adjustable Undershef

- Heavy gauge stainless steel.
- Gusset welded to each corner.
- Heavy duty marine edge design.

### Legs—1½" (41mm)-diameter

- Tables 96" (2438mm) and longer come with six legs or more.
- Heavy gauge stainless steel.
- 1" (25mm) adjustable stainless steel feet.

### Options / Accessories

- |  |  |
|--|--|
| <input type="checkbox"/> Drawer                                | <input type="checkbox"/> Duplex receptacles                            |
| <input type="checkbox"/> Lock                                  | <input type="checkbox"/> Pot rack                                      |
| <input type="checkbox"/> Casters                               | <input type="checkbox"/> Sink  |
| <input type="checkbox"/> Overshelves                           | <input type="checkbox"/> Additional undershef                          |
| <input type="checkbox"/> Knockdown Welded Base (see back page) | <input type="checkbox"/> Stabilizer Bar (for 30"- and 36"-wide tables) |

**EAGLE GROUP**  
100 Industrial Boulevard, Clayton, DE 19938-8903 USA  
Phone: 302-653-3000 • 800-441-8440 • Fax: 302-653-2065  
www.eaglegrp.com  
www.eaglehmc.com



For custom configuration or fabrication needs, contact our **SpecFAB®** Division.  
Phone: 302-653-3000 • Fax: 302-653-2065 • e-mail: quotes@eaglegrp.com

Eg10.41B Rev. 08/24

**Spec sheets available for viewing, printing or downloading from our online literature library at our websites**



Item No.: \_\_\_\_\_  
 Project No.: \_\_\_\_\_  
 S.I.S. No.: \_\_\_\_\_

# Worktables with Flat Top and Stainless Steel Base with Undershelf—Deluxe Series

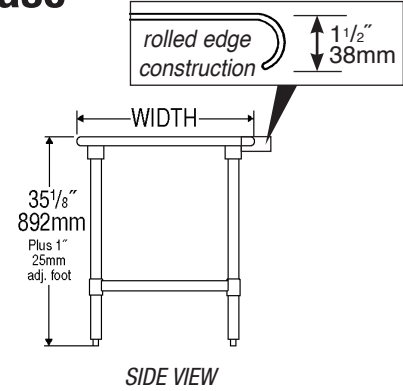
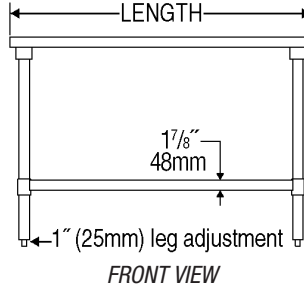
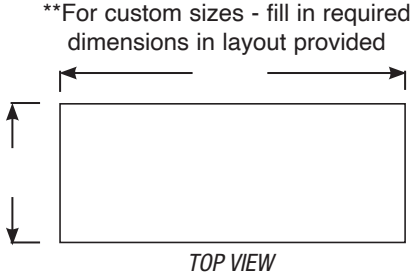

model #	# of legs	width		length		weight	
		in.	mm	in.	mm	lbs.	kg
T2424SEB	4	24"	610	24"	610	44	20.0
T2430SEB	4	24"	610	30"	762	51	23.1
T2436SEB	4	24"	610	36"	914	53	24.0
T2448SEB	4	24"	610	48"	1219	67	30.4
T2460SEB	4	24"	610	60"	1524	79	35.8
T2472SEB	4	24"	610	72"	1829	82	37.2
T2484SEB	4	24"	610	84"	2134	132	59.9
T2496SEB	6	24"	610	96"	2438	157	71.2
T24108SEB	6	24"	610	108"	2743	162	73.5
T24120SEB	6	24"	610	120"	3048	163	73.9
T24132SEB	8	24"	610	132"	3353	177	80.3
T24144SEB	8	24"	610	144"	3658	234	106.6
T3030SEB	4	30"	762	30"	762	55	25.0
T3036SEB	4	30"	762	36"	914	62	28.1
T3048SEB	4	30"	762	48"	1219	82	37.2
T3060SEB	4	30"	762	60"	1524	87	39.5
T3072SEB	4	30"	762	72"	1829	125	56.7
T3084SEB	4	30"	762	84"	2134	135	61.2
T3096SEB	6	30"	762	96"	2438	203	92.1
T30108SEB	6	30"	762	108"	2743	209	94.8
T30120SEB	6	30"	762	120"	3048	215	97.5
T30132SEB	8	30"	762	132"	3353	225	102.1
T30144SEB	8	30"	762	144"	3658	239	108.4
T3648SEB	4	36"	914	48"	1219	84	38.1
T3660SEB	4	36"	914	60"	1524	99	44.9
T3672SEB	4	36"	914	72"	1829	114	51.7
T3684SEB	4	36"	914	84"	2134	183	83.0
T3696SEB	6	36"	914	96"	2438	205	93.0
T36108SEB	6	36"	914	108"	2743	210	95.3
T36120SEB	6	36"	914	120"	3048	218	98.9
T36132SEB	8	36"	914	132"	3353	234	106.1
T36144SEB	8	36"	914	144"	3658	241	109.3

## NEW Option for Worktables with Stainless Steel Base: Knockdown Welded Base

**PATENT PENDING**

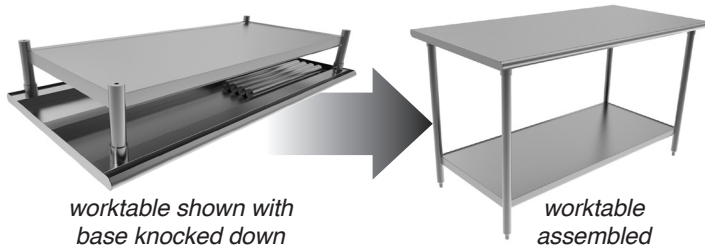

- Precision machined stainless steel threaded inserts pressed into 16 gauge 1 5/8"-diameter leg sections for knockdown construction
- Marine edge stainless steel undershelf welded to lower leg sections

Add suffix "-KDWB" to worktable model number (ex: T2436SEB-KDWB). See EG8217 for more info.

**EAGLE GROUP**  
 100 Industrial Boulevard, Clayton, DE 19938-8903 USA  
 Phone: 302-653-3000 or 800-441-8440 • Fax: 302-653-2065  
 www.eaglegrp.com • www.eaglehmc.com

Printed in U.S.A.  
 ©2024 by Eagle Group

Rev. 08/24

Spec sheets available for viewing, printing or downloading from our online literature library at our websites

Although every attempt has been made to ensure the accuracy of the information provided, we cannot be held responsible for typographical or printing errors. Information and specifications are subject to change without notice. Please confirm at time of order.