



Profit from the Eagle Advantage®

Specification Sheet

Short Form Specifications

Eagle Pizza Holding Table, model _____. Heavy duty stainless steel top, undershelf and overshelves. Two chrome plated wire racks, UL-listed infrared heat lamps. 1 1/2" O.D. stainless steel tubular legs with adjustable bullet feet.



pizza holding table

Options / Accessories

- Stainless steel bullet
- Additional undershelves

Item No.:	_____
Project No.:	_____
S.I.S. No.:	_____

Pizza Holding Tables

MODELS:

- PIH48-120
- PIH48-208
- PIH48-240

Overshelves

- U.L.-listed food warmers for 120V, 208V or 240V, single phase operation contain infrared lamps, each furnished with infinite control and rated at 675 watts either voltage.
- Field wiring to lamps furnished by others.
- Chrome-plated wire rack on bottom overshelf.

Tabletop

- Stainless steel.
- Chrome-plated wire rack.

Legs

- Heavy gauge stainless steel.
- 1 1/2" (41mm)-diameter.
- Adjustable metal feet.

Undershelf

- 18 gauge stainless steel
- Adjustable.

EAGLE GROUP

100 Industrial Boulevard, Clayton, DE 19938-8903 USA
 Phone: 302-653-3000 • 800-441-8440 • Fax: 302-653-2065
www.eaglegrp.com
www.eaglemhc.com

For custom configuration or fabrication needs, contact our SpecFAB® Division.
 Phone: 302-653-3000 • Fax: 302-653-2065 • e-mail: quotes@eaglegrp.com



EG10.20 Rev. 10/23

Spec sheets available for viewing, printing or downloading from our online literature library at our websites

Eagle Foodservice Equipment, Eagle MHC, and SpecFAB® are divisions of Eagle Group. ©2023 by the Eagle Group



Profit from the Eagle Advantage®

Item No.: _____
 Project No.: _____
 S.I.S. No.: _____

Pizza Holding Tables

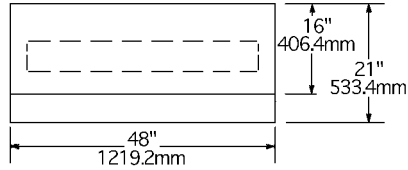

TOP VIEW

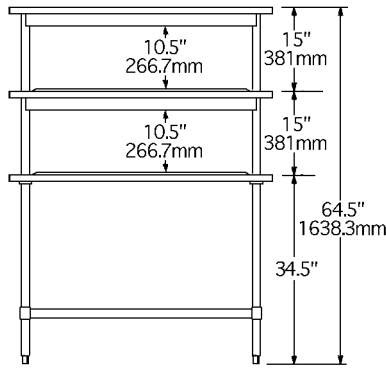

FRONT VIEW

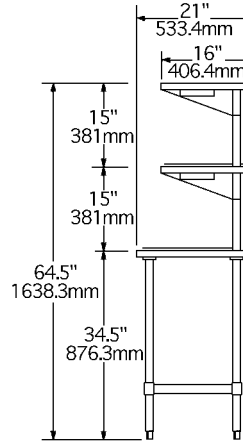

SIDE VIEW

Shipped knock down.
 All shipping weights are approximate.

model #	width		length		weight		voltage	amperage	watts
	in.	mm	in.	mm	lbs.	kg			
PIH48-120	21"	533	48"	1219	135	61.2	120 volts	5.62 amps	675 watts
PIH48-208	21"	533	48"	1219	135	61.2	208 volts	3.25 amps	675 watts
PIH48-240	21"	533	48"	1219	135	61.2	240 volts	2.82 amps	675 watts

Replacement Wire Racks

Chrome-plated.

model #	width x length		weight	
	in.	mm	lbs.	kg
WR-39	16" x 39"	406 x 991	6	2.7

EAGLE GROUP

100 Industrial Boulevard, Clayton, DE 19938-8903 USA

Phone: 302-653-3000 or 800-441-8440 • Fax: 302-653-2065

www.eaglegrp.com • www.eaglehmc.com

Printed in U.S.A.
 ©2023 by Eagle Group

Rev. 10/23

Spec sheets available for viewing, printing or downloading from our online literature library at our websites

Although every attempt has been made to ensure the accuracy of the information provided, we cannot be held responsible for typographical or printing errors. Information and specifications are subject to change without notice. Please confirm at time of order.