



Profit from the Eagle Advantage®

Specification Sheet

Short Form Specifications

Eagle Carry-Out Worktable, model TSC02460Z, to consist of heavy gauge galvanized tabletop and undershelf, one 1860Z EAGLEbrite® zinc-plated wire overshelf with 74" EAGLEbrite® zinc-plated rear posts, six shelf dividers, two bin holders, two hanger rails, and 13 5"-deep supply bins.



Item No.:	_____
Project No.:	_____
S.I.S. No.:	_____

Carry-Out Worktable

MODELS:

TSC02460Z

- Keeps work-related items together.
- One 18" (457mm) full-length wire shelf for overhead storage. Shelf height can be adjusted.
- Six shelf dividers: 8" x 18" (203 x 457mm)
- 13 plastic supply bins: 10³/₈" L x 5¹/₂" W x 5" D (276 x 140 x 127mm).
- Two chrome-plated full-length bin holders. Heights can be adjusted.
- Two 18" (457mm) hanger rails.
- All posts are numbered and grooved at 1" (25mm) increments for fast and level assembly.
- 18 gauge galvanized steel tabletop and undershelf, both with aluminum corner castings.
- 74" (1880mm) overall post height.
- 34" (864mm) working height.
- Wire overshelf, dividers, hanger rails and posts are zinc-plated.

EAGLE GROUP

100 Industrial Boulevard, Clayton, DE 19938-8903 USA
 Phone: 302-653-3000 • 800-441-8440 • Fax: 302-653-2065
www.eaglegrp.com
www.eaglegrpnews.com
www.eaglemhc.com

For custom configuration or fabrication needs, contact our **SpecFAB® Division**.
 Phone: 302-653-3000 • Fax: 302-653-2065 • e-mail: quotes@eaglegrp.com





Item No.: _____
 Project No.: _____
 S.I.S. No.: _____

Carry-Out Worktable

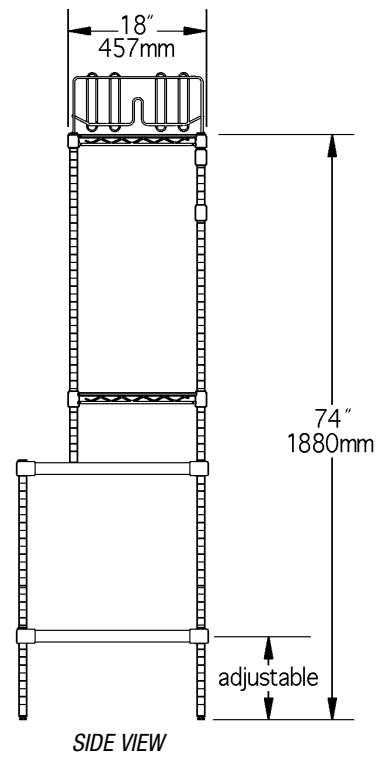
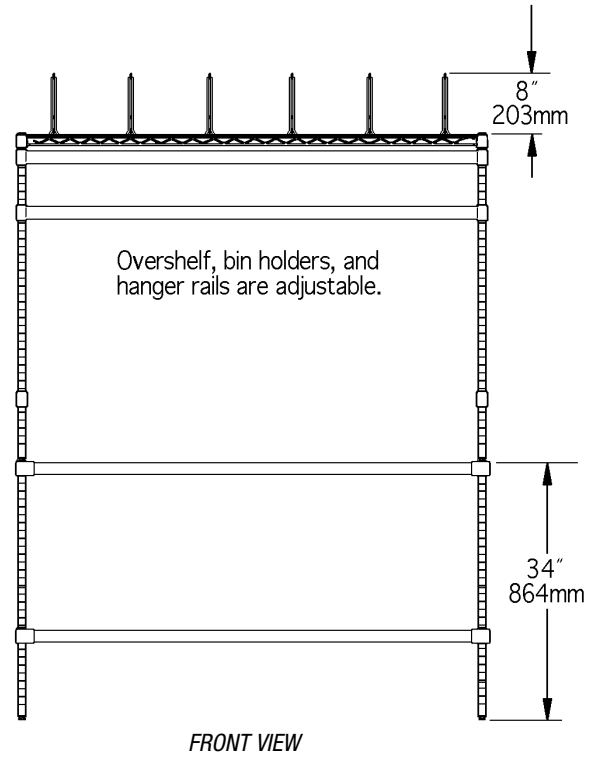
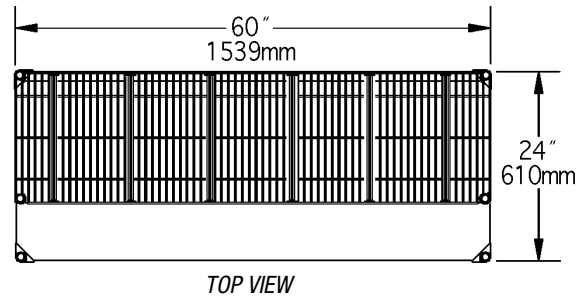

(Note: shown without supply bins)

model #	width		length		height *		weight	
	in.	mm	in.	mm	in.	mm	lbs.	kg
TSCO2460Z	24"	610	60"	1524	74"	1880	138	62.6

* Excludes dividers mounted on overshelf.

EAGLE GROUP
 100 Industrial Boulevard, Clayton, DE 19938-8903 USA
 Phone: 302-653-3000 or 800-441-8440 • Fax: 302-653-2065
 www.eaglegrp.com • www.eaglegrpnews.com • www.eaglehmc.com

Printed in U.S.A.
 ©2023 by Eagle Group
 Rev. 06/23

Spec sheets available for viewing, printing or downloading from our online literature library at our websites

Although every attempt has been made to ensure the accuracy of the information provided, we cannot be held responsible for typographical or printing errors. Information and specifications are subject to change without notice. Please confirm at time of order.