



Profit from the Eagle Advantage®

# Specification Sheet

## Short Form Specifications

Eagle Aluminum Beer Keg Rack, model \_\_\_\_\_. Heavy duty extruded aluminum construction with two heavy duty shelves for kegs, and a third shelf for general storage. Shelves are adjustable in 2" increments. Posts are 1 1/16"-diameter, marked in 2" increments with end caps on each end. Shipped knocked down.



aluminum beer keg rack

## Options / Accessories

- Additional shelves
- 3-sided frames
- Posts
- Floor post brackets

## EAGLE GROUP

100 Industrial Boulevard, Clayton, DE 19938-8903 USA  
 Phone: 302-653-3000 • 800-441-8440 • Fax: 302-653-2065  
[www.eaglegrp.com](http://www.eaglegrp.com)  
[www.eaglegrpnews.com](http://www.eaglegrpnews.com)  
[www.eaglemhc.com](http://www.eaglemhc.com)

For custom configuration or fabrication needs, contact our **SpecFAB® Division**.  
 Phone: 302-653-3000 • Fax: 302-653-2065 • e-mail: [quotes@eaglegrp.com](mailto:quotes@eaglegrp.com)

Item No.: \_\_\_\_\_  
 Project No.: \_\_\_\_\_  
 S.I.S. No.: \_\_\_\_\_

## Aluminum Beer Keg Racks

### MODELS:

- |                                   |                                   |                                   |                                 |
|-----------------------------------|-----------------------------------|-----------------------------------|---------------------------------|
| <input type="checkbox"/> KR1842A  | <input type="checkbox"/> KRS1860A | <input type="checkbox"/> KRB1880A | <input type="checkbox"/> KP54-A |
| <input type="checkbox"/> KR1860A  | <input type="checkbox"/> KRS1880A | <input type="checkbox"/> KRB1893A | <input type="checkbox"/> KP68-A |
| <input type="checkbox"/> KR1880A  | <input type="checkbox"/> KRS1893A | <input type="checkbox"/> KP12-A   | <input type="checkbox"/> KP72-A |
| <input type="checkbox"/> KR1893A  | <input type="checkbox"/> KRB1842A | <input type="checkbox"/> KP34-A   | <input type="checkbox"/> KP76-A |
| <input type="checkbox"/> KRS1842A | <input type="checkbox"/> KRB1860A | <input type="checkbox"/> KP48-A   | <input type="checkbox"/> KP84-A |
|                                   |                                   |                                   | <input type="checkbox"/> 374136 |

### Design and Construction Features

- Compatible with any wet or dry storage environment.
- Resists corrosion and rust.
- Heavy duty, high-tensile extruded aluminum, type 6063-T5 alloy.
- Racks feature three shelves – two of which are heavy duty for kegs and the third (usually on top) is for general storage.
- Heavy duty shelves: Rectangular frame of 1 1/2" x 2 3/4" x 0.07" (38 x 70 x 2mm) wall extruded aluminum square tube, with 1 1/4" x 2 1/2" x 0.10" (32 x 57 x 3mm) T-bars welded inside perpendicular to shelf length. 3" (76mm) spacing between T-bars.
- Top general storage shelf: Rectangular frame of 1 1/2" x 1 3/4" x 0.07" (38 x 45 x 2mm) wall extruded aluminum square tube, with 1 1/4" x 2 1/2" x 0.10" (32 x 57 x 3mm) T-bars welded inside. 3" (76mm) spacing between T-bars.
- Shelves are adjustable in 2" (51mm) increments. Each shelf corner has a welded-in-place heavy duty extruded aluminum collar with set screw.
- Posts are 1 1/16" (33mm) diameter, marked in 2" (51mm) increments, and include end cap on each end.
- Shipped knocked down, and assembles easily with allen wrench provided.

### Certifications / Approvals



AutoQuotes



EG01.38 Rev. 10/23

Spec sheets available for viewing, printing or downloading from our online literature library at our websites



Profit from the Eagle Advantage®

Item No.: \_\_\_\_\_  
 Project No.: \_\_\_\_\_  
 S.I.S. No.: \_\_\_\_\_

# Aluminum Beer Keg Racks

## Corner of Top Shelf (used for general storage)

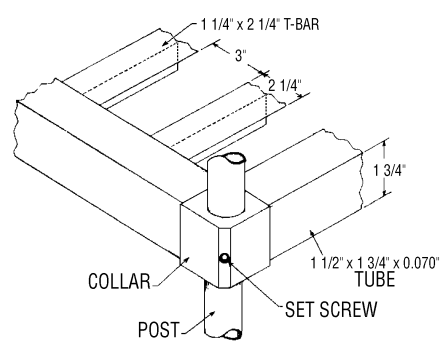

## Corner of Heavy Duty Shelves (used for kegs)

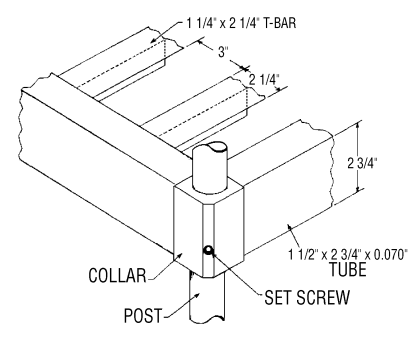

model #	width		length		height		weight		keg capacity
	in.	mm	in.	mm	in.	mm	lbs.	kg	
<b>KR1842A</b>	18"	457	42"	1067	76"	1930	41	18.6	4
<b>KR1860A</b>	18"	457	60"	1524	76"	1930	64	29.0	6
<b>KR1880A</b>	18"	457	80"	2032	76"	1930	78	35.4	8
<b>KR1893A*</b>	18"	457	93"	2362	76"	1930	93	42.2	10

\* 93" (2362mm)-long units feature six posts. Mid posts are protruded. Add 6" to width.

## Replacement Components

### Heavy Duty Shelves

model #	width		length		weight		keg capacity
	in.	mm	in.	mm	lbs.	kg	
<b>KRS1842A</b>	18"	457	42"	1067	12	5.4	2
<b>KRS1860A</b>	18"	457	60"	1524	15	6.8	3
<b>KRS1880A</b>	18"	457	80"	2032	19	8.6	4
<b>KRS1893A*</b>	18"	457	93"	2362	23	10.4	5

\* 93" (2362mm)-long shelves feature front and rear protruded collars midway of shelf, which add 6" (152mm) to width.

### Posts

model #	height		weight	
	in.	mm	lbs.	kg
<b>KP12-A</b>	12"	305	0.6	0.3
<b>KP34-A</b>	34"	864	2.0	0.9
<b>KP48-A</b>	48"	1219	2.5	1.1
<b>KP54-A</b>	54"	1372	3.0	1.4
<b>KP68-A</b>	68"	1727	3.5	1.6
<b>KP72-A</b>	72"	1829	3.5	1.6
<b>KP76-A</b>	76"	1930	4.0	1.8
<b>KP84-A</b>	84"	2134	4.5	2.0

### 3-Sided Frames

model #	width		length		weight	
	in.	mm	in.	mm	lbs.	kg
<b>KRB1842A</b>	18"	457	42"	1067	5	2.3
<b>KRB1860A</b>	18"	457	60"	1524	8	3.6
<b>KRB1880A</b>	18"	457	80"	2032	9	4.1
<b>KRB1893A*</b>	18"	457	93"	2362	10	4.5

\* 93" (2362mm)-long frames feature front and rear protruded collars midway, which add 6" (152mm) to width.

### Floor Post Brackets

model #	weight	
	lbs.	kg
<b>374136</b>	0.5	0.23

### EAGLE GROUP

100 Industrial Boulevard, Clayton, DE 19938-8903 USA  
 Phone: 302-653-3000 or 800-441-8440 • Fax: 302-653-2065  
 www.eaglegrp.com • www.eaglegrpnews.com • www.eaglehmc.com

Printed in U.S.A.  
 ©2023 by Eagle Group  
 Rev. 10/23

Spec sheets available for viewing, printing or downloading from our online literature library at our websites

Although every attempt has been made to ensure the accuracy of the information provided, we cannot be held responsible for typographical or printing errors. Information and specifications are subject to change without notice. Please confirm at time of order.