



Profit from the Eagle Advantage®

# Specification Sheet

## Short Form Specifications

Eagle QuadPLUS®, model \_\_\_\_\_. Consists of (1) Standard truss frame with louvered QuadPLUS® green shelf mats; (3) Quad-Adjust® truss frames with louvered QuadPLUS® green shelf mats; (1) Standard truss frame with solid QuadPLUS® green shelf mats; and (4) 74" (1880mm) posts. Mobile units feature 5" (127mm) resilient swivel stem casters—two with brake.



QuadPLUS® stationary starter unit

## Options / Accessories

- Dividers
- Wire Baskets

## EAGLE GROUP

100 Industrial Boulevard, Clayton, DE 19938-8903 USA  
 Phone: 302-653-3000 • 800-441-8440 • Fax: 302-653-2065  
[www.eaglegrp.com](http://www.eaglegrp.com)  
[www.eaglegrpnews.com](http://www.eaglegrpnews.com)  
[www.eaglemhc.com](http://www.eaglemhc.com)

For custom configuration or fabrication needs, contact our **SpecFAB® Division**.  
 Phone: 302-653-3000 • Fax: 302-653-2065 • e-mail: [quotes@eaglegrp.com](mailto:quotes@eaglegrp.com)

Item No.:	_____
Project No.:	_____
S.I.S. No.:	_____

# QuadPLUS® 5-Tier Starter Units

## MODELS:

- |   |   |
|---|---|
| <input type="checkbox"/> QPMU18*C-G5-74 | <input type="checkbox"/> QPSU18*C-G5-74 |
| <input type="checkbox"/> QPMU21*C-G5-74 | <input type="checkbox"/> QPSU24*C-G5-74 |
| <input type="checkbox"/> QPMU24*C-G5-74 | <input type="checkbox"/> QPSU21*C-G5-74 |
| <input type="checkbox"/> QPMU18*V-G5-74 | <input type="checkbox"/> QPSU18*V-G5-74 |
| <input type="checkbox"/> QPMU21*V-G5-74 | <input type="checkbox"/> QPSU24*V-G5-74 |
| <input type="checkbox"/> QPMU24*V-G5-74 | <input type="checkbox"/> QPSU21*V-G5-74 |

\* See charts below for complete model numbers.

## Features

- (1) Standard truss frame with louvered QuadPLUS® green shelf mats.
- (3) Quad-Adjust® truss frames with louvered QuadPLUS® green shelf mats.
- (1) Standard truss frame with solid QuadPLUS® green shelf mats.
- (4) 74" (1880mm) posts.
- Stationary and mobile units available. Mobile units feature 5" (127mm) resilient swivel stem casters—two with brake.
- Mats lay securely on top of truss frame or on top of an existing standard wire shelf.
- Truss frames and shelves adjustable at 1" increments to accommodate many applications.
- Injection-molded polypropylene mats feature MICROGARD® antimicrobial protection against bacteria, mold and mildew.
- Easy cleaning, dishwasher-safe.
- Truss frames coated with EAGLEgard® green epoxy or Valu-Gard® green epoxy finish.
- Set of four split sleeves (included with each truss frame) snap onto Eagle's 1"-diameter posts.
- Temperature rating: Up to 200°F\* for intermittent exposure to cleaning, such as in a dishwasher.

\* Temperature rating of -20°F to 120°F under continuous use.

## Certifications / Approvals



Spec sheets available for viewing, printing or downloading from our online literature library at our websites



Item No.: \_\_\_\_\_  
 Project No.: \_\_\_\_\_  
 S.I.S. No.: \_\_\_\_\_

# QuadPLUS® 5-Tier Starter Units

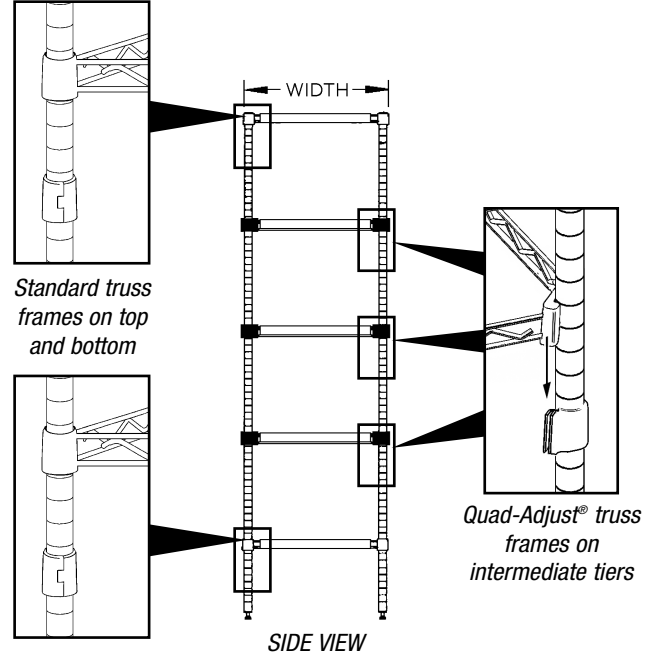
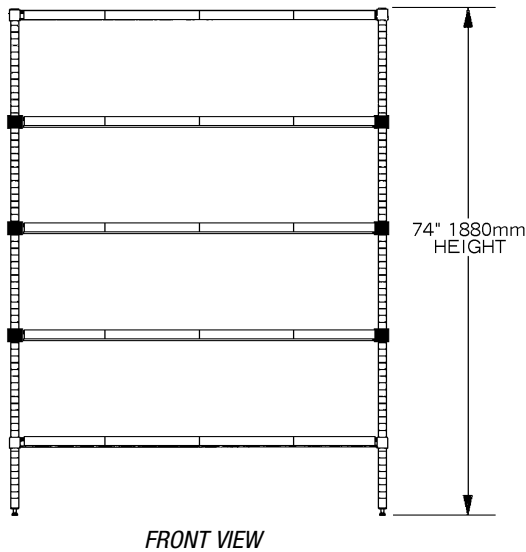
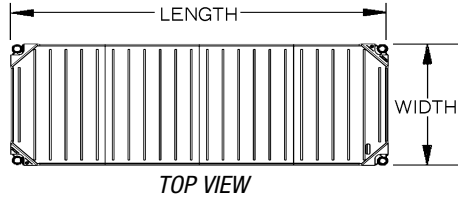

(stationary shelf unit shown)

width x length in. mm	...with EAGLEgard® green epoxy		...with Valu-Gard® green epoxy	
	STATIONARY model #	MOBILE model #	STATIONARY model #	MOBILE model #
18" x 36" 457 x 914	QPSU1836E-G5-74	QPMU1836E-G5-74	QPSU1836VG-G5-74	QPMU1836VG-G5-74
18" x 48" 457 x 1219	QPSU1848E-G5-74	QPMU1848E-G5-74	QPSU1848VG-G5-74	QPMU1848VG-G5-74
18" x 60" 457 x 1524	QPSU1860E-G5-74	QPMU1860E-G5-74	QPSU1860VG-G5-74	QPMU1860VG-G5-74
21" x 36" 533 x 914	QPSU2136E-G5-74	QPMU2136E-G5-74	QPSU2136VG-G5-74	QPMU2136VG-G5-74
21" x 48" 533 x 1219	QPSU2148E-G5-74	QPMU2148E-G5-74	QPSU2148VG-G5-74	QPMU2148VG-G5-74
21" x 60" 533 x 1524	QPSU2160E-G5-74	QPMU2160E-G5-74	QPSU2160VG-G5-74	QPMU2160VG-G5-74
24" x 36" 610 x 914	QPSU2436E-G5-74	QPMU2436E-G5-74	QPSU2436VG-G5-74	QPMU2436VG-G5-74
24" x 48" 610 x 1219	QPSU2448E-G5-74	QPMU2448E-G5-74	QPSU2448VG-G5-74	QPMU2448VG-G5-74
24" x 60" 610 x 1524	QPSU2460E-G5-74	QPMU2460E-G5-74	QPSU2460VG-G5-74	QPMU2460VG-G5-74

**EAGLE GROUP**  
 100 Industrial Boulevard, Clayton, DE 19938-8903 USA  
 Phone: 302-653-3000 or 800-441-8440 • Fax: 302-653-2065  
 www.eaglegrp.com • www.eaglegrpnews.com • www.eaglehmc.com

Printed in U.S.A.  
 ©2023 by Eagle Group  
 Rev. 10/23

**Spec sheets available for viewing, printing or downloading from our online literature library at our websites**

Although every attempt has been made to ensure the accuracy of the information provided, we cannot be held responsible for typographical or printing errors. Information and specifications are subject to change without notice. Please confirm at time of order.