



Profit from the Eagle Advantage®

Specification Sheet

Short Form Specifications

Eagle Wire Basket Utility Cart, model WBC1836C-1B1W. Furnished with one chrome finish open-wire design basket shelf and one chrome finish wire shelf with patented QuadTruss® design, mounted on chrome posts with swivel stem casters, donut bumpers, and two push handles.

Eagle Wire Basket Utility Cart, model WBC1836C-2B. Furnished with two chrome finish open-wire design basket shelves, chrome posts, swivel casters, donut bumpers, and two push handles.



#WBC1836C-1B1W
one basket shelf and one standard shelf

Options / Accessories *

- Additional basket shelves
- Additional wire shelves
- Dividers
- Plastic Shelf Markers

* See Spec Sheets #EG01.03A-E for more options and accessories for Eagle Wire Shelving.

EAGLE GROUP

100 Industrial Boulevard, Clayton, DE 19938-8903 USA
Phone: 302-653-3000 • 800-441-8440 • Fax: 302-653-2065
www.eaglegrp.com
www.eaglegrpnews.com
www.eaglemhc.com

For custom configuration or fabrication needs, contact our SpecFAB® Division.
Phone: 302-653-3000 • Fax: 302-653-2065 • e-mail: quotes@eaglegrp.com

Item No.: _____
Project No.: _____
S.I.S. No.: _____

Wire Basket Utility Carts

MODELS:

- WBC1836C-1B1W
- WBC1836C-2B

Design and Construction Features—Both Models:

- Perfect for light duty applications where easy accessibility of products is required.
- Chrome plated finish.
- Open wire construction permits greater air circulation, which helps reduce moisture and dust buildup.
- Swivel stem casters with bumpers.
- Two push handles.
- Wire basket shelf is 18" x 36" x 4¼" (457 x 914 x 107mm).
- 36½" (927mm) overall cart height.

#WBC1836C-1B1W:

- One basket shelf.
- One standard wire shelf with patented QuadTruss® design (patent #5,390,803).

#WBC1836C-2B:

- Two basket shelves.

Certifications / Approvals



AutoQuotes



EG01.35 Rev. 06/23

Spec sheets available for viewing, printing or downloading from our online literature library at our websites

Eagle Foodservice Equipment, Eagle MHC, and SpecFAB® are divisions of Eagle Group. ©2023 by the Eagle Group



Item No.: _____
 Project No.: _____
 S.I.S. No.: _____

Wire Basket Utility Carts

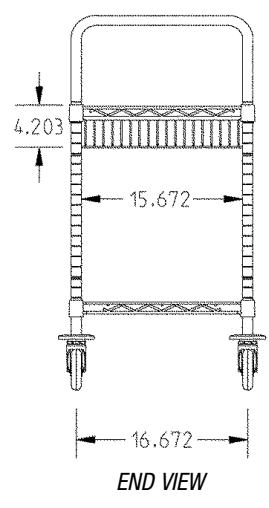
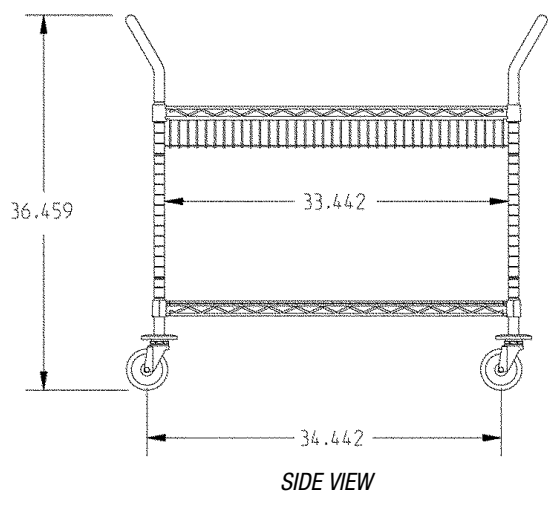
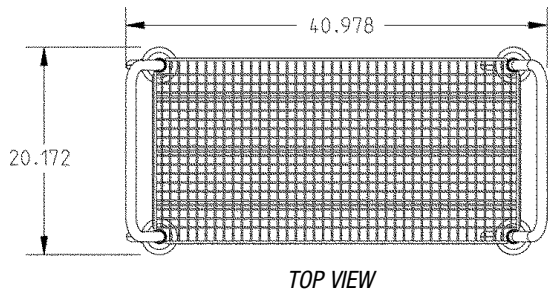

(model # WBC1836C-1B1W shown)

description	weight		model #
	lbs.	kg	
1 chrome basket shelf, 1 chrome standard shelf	31	14.1	WBC1836C-1B1W
2 chrome basket shelves	32	14.5	WBC1836C-2B

EAGLE GROUP
 100 Industrial Boulevard, Clayton, DE 19938-8903 USA
 Phone: 302-653-3000 or 800-441-8440 • Fax: 302-653-2065
 www.eaglegrp.com • www.eaglegrpnews.com • www.eaglemhc.com

Printed in U.S.A.
 ©2023 by Eagle Group
 Rev. 06/23

Spec sheets available for viewing, printing or downloading from our online literature library at our websites

Although every attempt has been made to ensure the accuracy of the information provided, we cannot be held responsible for typographical or printing errors. Information and specifications are subject to change without notice. Please confirm at time of order.