



Profit from the Eagle Advantage®

Specification Sheet

Short Form Specifications

Eagle Spec-Bar® Closed Base Workboard, model _____. Heavy gauge type 304 stainless steel cabinet body, legs, leg channels, and doors. Stainless steel hinged doors with locks, and adjustable stainless steel shelf. Top has 1½" drain with stainless steel removable perforated insert. Stainless steel adjustable bullet feet.

Eagle Spec-Bar 2000® Open Base Workboard, model _____. Heavy gauge type 304 stainless steel cabinet body, legs, and leg channels. Top has 1½" drain with stainless steel removable perforated insert. Stainless steel adjustable bullet feet.



Item No.:	_____
Project No.:	_____
S.I.S. No.:	_____

Spec-Bar® Workboard Cabinets

MODELS:

- | | |
|------------------------------------|------------------------------------|
| <input type="checkbox"/> WBCB24-19 | <input type="checkbox"/> WBOB24-19 |
| <input type="checkbox"/> WBCB24-24 | <input type="checkbox"/> WBOB24-24 |
| <input type="checkbox"/> WBCB30-19 | <input type="checkbox"/> WBOB30-19 |
| <input type="checkbox"/> WBCB30-24 | <input type="checkbox"/> WBOB30-24 |
| <input type="checkbox"/> WBCB36-19 | <input type="checkbox"/> WBOB36-19 |
| <input type="checkbox"/> WBCB36-24 | <input type="checkbox"/> WBOB36-24 |
| <input type="checkbox"/> WBCB42-19 | <input type="checkbox"/> WBOB42-19 |
| <input type="checkbox"/> WBCB42-24 | <input type="checkbox"/> WBOB42-24 |
| <input type="checkbox"/> WBCB48-19 | <input type="checkbox"/> WBOB48-19 |
| <input type="checkbox"/> WBCB48-24 | <input type="checkbox"/> WBOB48-24 |

Design and Construction Features

- Body, legs and crossbracing constructed of type 304 stainless steel for strength and corrosion resistance.
- Backsplash, bottom, sides, trim rail, shelf, drain pan and perforated insert are 20 gauge stainless steel.
- Leg mounting channels, legs and crossbracing are 16 gauge stainless steel.
- Legs are 1½" (41mm)-diameter, with stainless steel adjustable bullet feet.
- Shelf is stainless steel and adjustable.
- Cabinet has workboard surface with removable stainless insert.
- Available with or without hinged doors.
- 1½" (38mm) I.P.S. threaded drain with nut and washer.

EAGLE GROUP
100 Industrial Boulevard, Clayton, DE 19938-8903 USA
Phone: 302-653-3000 • Fax: 302-653-2065
www.eaglegrp.com

Foodservice Division: Phone 800-441-8440
MHC/Retail Display Divisions: Phone 800-637-5100

For custom configuration or fabrication needs, contact our **SpecFAB® Division**.
Phone: 302-653-3000 • Fax: 302-653-3091 • e-mail: specfab@eaglegrp.com



AUTOQUOTES



EG40.32 Rev. 04/11

Spec sheets available for viewing, printing or downloading from our online literature library at www.eaglegrp.com

Eagle Foodservice Equipment, Eagle MHC, SpecFAB®, and Retail Display are divisions of Eagle Group. ©2011 by the Eagle Group



Profit from the Eagle Advantage®

Item No.: _____
 Project No.: _____
 S.I.S. No.: _____

Spec-Bar® Workboard Cabinets

19" (483mm)-wide Units

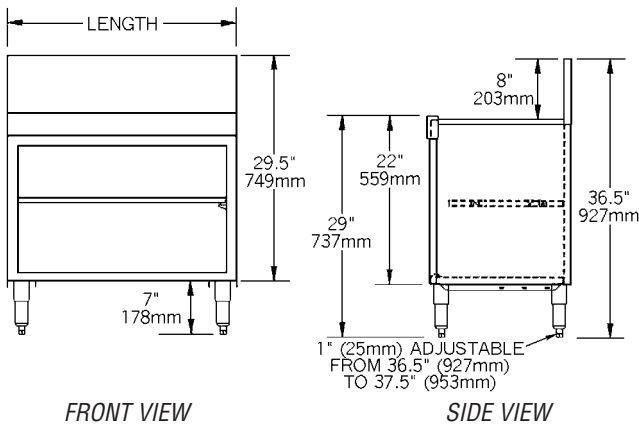
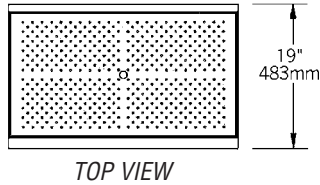

Note: model with open base shown

...with Closed Base*

model #	width		length		weight	
	in.	mm	in.	mm	lbs.	kg
WBCB24-19	19"	483	24"	610	50	22.7
WBCB30-19	19"	483	30"	762	55	24.9
WBCB36-19	19"	483	36"	914	60	27.2
WBCB42-19	19"	483	42"	1067	65	29.5
WBCB48-19	19"	483	48"	1219	70	31.8

*Locks are standard

...with Open Base

model #	width		length		weight	
	in.	mm	in.	mm	lbs.	kg
WBOB24-19	19"	483	24"	610	45	20.4
WBOB30-19	19"	483	30"	762	50	22.7
WBOB36-19	19"	483	36"	914	55	24.9
WBOB42-19	19"	483	42"	1067	60	27.2
WBOB48-19	19"	483	48"	1219	65	29.5

24" (610mm)-wide Units

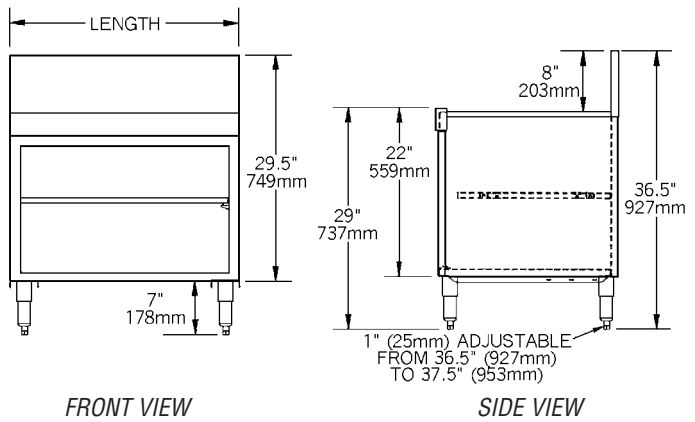
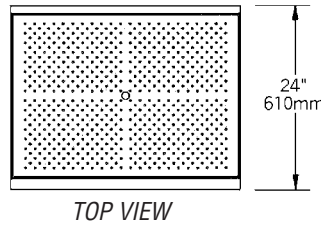

Note: model with open base shown

...with Closed Base*

model #	width		length		weight	
	in.	mm	in.	mm	lbs.	kg
WBCB24-24	24"	610	24"	610	55	24.9
WBCB30-24	24"	610	30"	762	60	27.2
WBCB36-24	24"	610	36"	914	65	29.5
WBCB42-24	24"	610	42"	1067	70	31.8
WBCB48-24	24"	610	48"	1219	75	34.0

*Locks are standard

...with Open Base

model #	width		length		weight	
	in.	mm	in.	mm	lbs.	kg
WBOB24-24	24"	610	24"	610	50	22.7
WBOB30-24	24"	610	30"	762	55	24.9
WBOB36-24	24"	610	36"	914	60	27.2
WBOB42-24	24"	610	42"	1067	65	29.5
WBOB48-24	24"	610	48"	1219	70	31.8

EAGLE GROUP

100 Industrial Boulevard, Clayton, DE 19938-8903 USA

Phone: 302-653-3000 • Fax: 302-653-2065

www.eaglegrp.com

Foodservice Division: Phone 800-441-8440

MHC/Retail Display Divisions: Phone 800-637-5100

Printed in U.S.A.
 ©2011 by Eagle Group

Rev. 04/11

Spec sheets available for viewing, printing or downloading from our online literature library at www.eaglegrp.com

Although every attempt has been made to ensure the accuracy of the information provided, we cannot be held responsible for typographical or printing errors. Information and specifications are subject to change without notice. Please confirm at time of order.