



Profit from the Eagle Advantage®

Specification Sheet

Short Form Specifications

Eagle (One-, Two-, Three-, Four-Compartment) Seamless Welded-In Sink, model _____. Sinks are heavy gauge type 300 stainless steel. 1" outside flanges. On units of two or more bowls, space is 2" between bowls. Provided with 3½" basket drain.



Options / Accessories

- P-trap
- Tail piece
- Lever drains
- Sound deadening (add suffix "-SD")
- Overflow hole (add suffix "-OF")
- Twist or lever drain bracket (add suffix "-TB")

EAGLE GROUP

100 Industrial Boulevard, Clayton, DE 19938-8903 USA
 Phone: 302-653-3000 • 800-441-8440 • Fax: 302-653-2065
 www.eaglegrp.com
 www.eaglehmc.com

For custom configuration or fabrication needs, contact our SpecFAB® Division.
 Phone: 302-653-3000 • Fax: 302-653-2065 • e-mail: quotes@eaglegrp.com

Item No.: _____
 Project No.: _____
 S.I.S. No.: _____

Seamless Welded-In Sinks

MODELS:

- | | | |
|---|---|---|
| <input type="checkbox"/> FDI-10-14-5-1 | <input type="checkbox"/> FDI-10-14-9.5-2 | <input type="checkbox"/> FDI-16-19-13.5-3 |
| <input type="checkbox"/> FDI-10-14-9.5-1 | <input type="checkbox"/> FDI-12-14-9.5-2 | <input type="checkbox"/> FDI-18-24-13.5-3 |
| <input type="checkbox"/> FDI-12-14-9.5-1 | <input type="checkbox"/> FDI-14-16-9.5-2 | <input type="checkbox"/> FDI-22-22-13.5-3 |
| <input type="checkbox"/> FDI-12-20-6.5-1 | <input type="checkbox"/> FDI-16-19-8-2 | <input type="checkbox"/> FDI-24-24-13.5-3 |
| <input type="checkbox"/> FDI-14-16-9.5-1 | <input type="checkbox"/> FDI-16-19-13.5-2 | <input type="checkbox"/> FDI-10-14-9.5-4 |
| <input type="checkbox"/> FDI-14-16-6-1 | <input type="checkbox"/> FDI-18-24-13.5-2 | <input type="checkbox"/> FDI-12-14-9.5-4 |
| <input type="checkbox"/> FDI-16-19-8-1 | <input type="checkbox"/> FDI-22-22-13.5-2 | <input type="checkbox"/> FDI-14-16-9.5-4 |
| <input type="checkbox"/> FDI-16-19-13.5-1 | <input type="checkbox"/> FDI-24-24-13.5-2 | <input type="checkbox"/> FDI-16-19-8-4 |
| <input type="checkbox"/> FDI-18-24-13.5-1 | <input type="checkbox"/> FDI-10-14-9.5-3 | <input type="checkbox"/> FDI-16-19-13.5-4 |
| <input type="checkbox"/> FDI-20-20-5-1 | <input type="checkbox"/> FDI-12-14-9.5-3 | <input type="checkbox"/> FDI-18-24-13.5-4 |
| <input type="checkbox"/> FDI-22-22-13.5-1 | <input type="checkbox"/> FDI-14-16-9.5-3 | <input type="checkbox"/> FDI-22-22-13.5-4 |
| <input type="checkbox"/> FDI-24-24-13.5-1 | <input type="checkbox"/> FDI-16-19-8-3 | <input type="checkbox"/> FDI-24-24-13.5-4 |

Design and Construction Features

- For NSF-approved welded fabrication.
- Seamless construction.
- Large radius bowl construction.
- Outside flanges are 1" (25mm) on all units.
- On units with two or more sink bowls, space between bowls is 2" (51mm).
- Type 300 stainless steel all-welded construction.

For Undermount...

An understructure is secured atop cabinet, then the sink's flanges are secured between understructure and countertop.

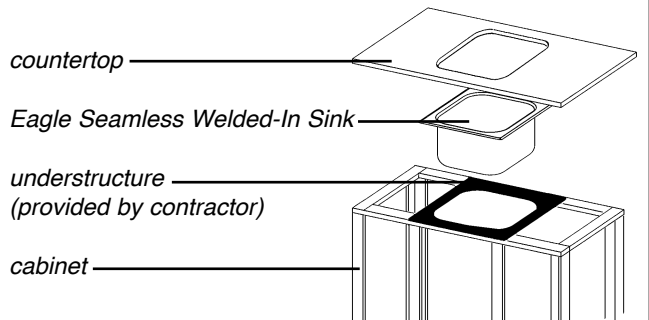

Certifications / Approvals



EG20.18 Rev. 01/24

Spec sheets available for viewing, printing or downloading from our online literature library at our websites

Eagle Foodservice Equipment, Eagle MHC, and SpecFAB® are divisions of Eagle Group. ©2024 by the Eagle Group



Profit from the Eagle Advantage®

 Item No.: _____
 Project No.: _____
 S.I.S. No.: _____

One-Compartment Sinks

model #	inside bowl dimensions width x length x depth		overall dimensions width x length		gauge	drain diameter		weight	
	in.	mm	in.	mm		in.	mm	lbs.	kg
FDI-10-14-5-1	14" x 10" x 5"	356 x 254 x 127	16" x 12"	406 x 305	20	3½"	89	9	4.1
FDI-10-14-9.5-1	14" x 10" x 9½"	356 x 254 x 241	16" x 12"	406 x 305	18	3½"	89	11	5.0
FDI-12-14-9.5-1	14" x 12" x 9½"	356 x 305 x 241	16" x 14"	406 x 356	16	3½"	89	13	5.8
FDI-12-20-6.5-1	20" x 12" x 6½"	508 x 305 x 165	22" x 14"	559 x 356	20	2"	51	14	6.4
FDI-14-16-9.5-1	16" x 14" x 9½"	406 x 356 x 241	18" x 16"	457 x 406	16	3½"	89	14	6.4
FDI-14-16-6-1	16" x 14" x 6"	406 x 356 x 152	18" x 16"	457 x 406	20	3½"	89	14	6.4
FDI-16-19-8-1	20" x 16" x 8"	508 x 406 x 203	21¾" x 18"	552 x 457	18	3½"	89	23	10.4
FDI-16-19-13.5-1	20" x 16" x 13½"	508 x 406 x 343	21¾" x 18"	552 x 457	18	3½"	89	25	11.3
FDI-18-24-13.5-1	24" x 18" x 13½"	610 x 457 x 343	26" x 20"	660 x 508	18	3½"	89	37	16.8
FDI-20-20-5-1	20" x 20" x 5"	508 x 508 x 127	22" x 22"	559 x 559	20	3½"	89	19	8.6
FDI-22-22-13.5-1	22" x 22" x 13½"	559 x 559 x 343	24" x 24"	610 x 610	16	3½"	89	39	17.6
FDI-24-24-13.5-1	24" x 24" x 13½"	610 x 610 x 343	26" x 26"	660 x 660	18	3½"	89	41	18.6

Two-Compartment Sinks

model #	inside bowl dimensions width x length x depth		overall dimensions width x length		gauge*	drain diameter		weight	
	in.	mm	in.	mm		in.	mm	lbs.	kg
FDI-10-14-9.5-2	14" x 10" x 9½"	356 x 254 x 241	16" x 24"	406 x 610	18	3½"	89	19	8.6
FDI-12-14-9.5-2	14" x 12" x 9½"	356 x 305 x 241	16" x 28"	406 x 711	16	3½"	89	21	9.5
FDI-14-16-9.5-2	16" x 14" x 9½"	406 x 356 x 241	18" x 32"	457 x 813	16	3½"	89	25	11.3
FDI-16-19-8-2	20" x 16" x 8"	508 x 406 x 203	21¾" x 36"	552 x 914	18	3½"	89	43	19.5
FDI-16-19-13.5-2	20" x 16" x 13½"	508 x 406 x 343	21¾" x 36"	552 x 914	18	3½"	89	50	22.7
FDI-18-24-13.5-2	24" x 18" x 13½"	610 x 457 x 343	26" x 40"	660 x 1016	18	3½"	89	73	33.1
FDI-22-22-13.5-2	22" x 22" x 13½"	559 x 559 x 343	24" x 48"	610 x 1219	16	3½"	89	75	34.0
FDI-24-24-13.5-2	24" x 24" x 13½"	610 x 610 x 343	26" x 52"	660 x 1321	18	3½"	89	81	36.7

Three-Compartment Sinks

model #	inside bowl dimensions width x length x depth		overall dimensions width x length		gauge*	drain diameter		weight	
	in.	mm	in.	mm		in.	mm	lbs.	kg
FDI-10-14-9.5-3	14" x 10" x 9½"	356 x 254 x 241	16" x 36"	406 x 914	18	3½"	89	27	12.2
FDI-12-14-9.5-3	14" x 12" x 9½"	356 x 305 x 241	16" x 42"	406 x 1067	16	3½"	89	30	13.6
FDI-14-16-9.5-3	16" x 14" x 9½"	406 x 356 x 241	18" x 48"	457 x 1219	16	3½"	89	36	16.3
FDI-16-19-8-3	20" x 16" x 8"	508 x 406 x 203	21¾" x 54"	552 x 1372	18	3½"	89	63	28.6
FDI-16-19-13.5-3	20" x 16" x 13½"	508 x 406 x 343	21¾" x 54"	552 x 1372	18	3½"	89	75	34.0
FDI-18-24-13.5-3	24" x 18" x 13½"	610 x 457 x 343	26" x 60"	660 x 1524	18	3½"	89	101	45.8
FDI-22-22-13.5-3	22" x 22" x 13½"	559 x 559 x 343	24" x 72"	610 x 1829	16	3½"	89	113	51.3
FDI-24-24-13.5-3	24" x 24" x 13½"	610 x 610 x 343	26" x 78"	660 x 1981	18	3½"	89	123	55.8

Four-Compartment Sinks

model #	inside bowl dimensions width x length x depth		overall dimensions width x length		gauge*	drain diameter		weight	
	in.	mm	in.	mm		in.	mm	lbs.	kg
FDI-10-14-9.5-4	14" x 10" x 9½"	356 x 254 x 241	16" x 48"	406 x 1219	18	3½"	89	35	15.9
FDI-12-14-9.5-4	14" x 12" x 9½"	356 x 305 x 241	16" x 56"	406 x 1422	16	3½"	89	39	17.6
FDI-14-16-9.5-4	16" x 14" x 9½"	406 x 356 x 241	18" x 64"	457 x 1626	16	3½"	89	47	21.3
FDI-16-19-8-4	20" x 16" x 8"	508 x 406 x 203	21¾" x 72"	552 x 1829	18	3½"	89	83	37.6
FDI-16-19-13.5-4	20" x 16" x 13½"	508 x 406 x 343	21¾" x 72"	552 x 1829	18	3½"	89	100	45.4
FDI-18-24-13.5-4	24" x 18" x 13½"	610 x 457 x 343	26" x 80"	660 x 3032	18	3½"	89	129	58.5
FDI-22-22-13.5-4	22" x 22" x 13½"	559 x 559 x 343	24" x 96"	610 x 2438	16	3½"	89	151	68.6
FDI-24-24-13.5-4	24" x 24" x 13½"	610 x 610 x 343	26" x 104"	660 x 2642	18	3½"	89	163	73.9

* 16 gauge bowls are fabricated. 18 gauge bowls are deep-drawn.

Specifications subject to change without prior notice.

EAGLE GROUP

100 Industrial Boulevard, Clayton, DE 19938-8903 USA

Phone: 302-653-3000 or 800-441-8440 • Fax: 302-653-2065

www.eaglegrp.com • www.eaglehmc.com

Printed in U.S.A.

©2024 by Eagle Group

Rev. 01/24

Spec sheets available for viewing, printing or downloading from our online literature library at our websites

Although every attempt has been made to ensure the accuracy of the information provided, we cannot be held responsible for typographical or printing errors. Information and specifications are subject to change without notice. Please confirm at time of order.