



Profit from the Eagle Advantage®

Specification Sheet

Short Form Specifications

Eagle worktables, Spec-Master® series, model _____.
 Top constructed of 14 gauge 300 series stainless steel with 1½" roll on front and rear, and sides turned down 90°. Open front with 1¼" O.D. galvanized tubular crossbracing on sides and rear. Top reinforced with welded hat channels and sound deadened. Constructed with uni-lok® patented gusset system with the gussets recessed into the hat channels to reduce lateral movement. Legs are 1½" O.D. galvanized tubing, with galvanized gussets and 1" hi-impact plastic bullet feet.



worktable with flat top and tubular base

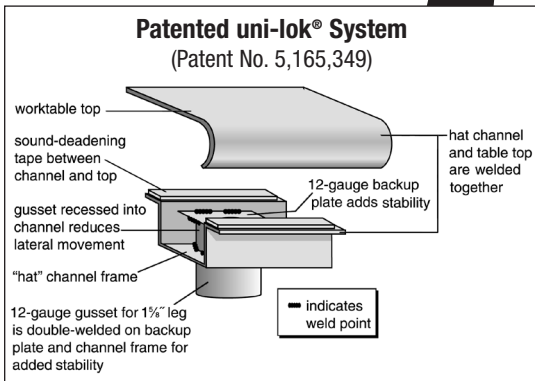

Item No.: _____
 Project No.: _____
 S.I.S. No.: _____

Worktables with Flat Top and Galvanized Tubular Base—Spec-Master® Series

MODELS:

- | | | | |
|------------------------------------|------------------------------------|------------------------------------|------------------------------------|
| <input type="checkbox"/> T2424GTE | <input type="checkbox"/> T24144GTE | <input type="checkbox"/> T30132GTE | <input type="checkbox"/> T36144GTE |
| <input type="checkbox"/> T2430GTE | <input type="checkbox"/> T3030GTE | <input type="checkbox"/> T30144GTE | <input type="checkbox"/> T4848GTE |
| <input type="checkbox"/> T2436GTE | <input type="checkbox"/> T3036GTE | <input type="checkbox"/> T3648GTE | <input type="checkbox"/> T4860GTE |
| <input type="checkbox"/> T2448GTE | <input type="checkbox"/> T3048GTE | <input type="checkbox"/> T3660GTE | <input type="checkbox"/> T4872GTE |
| <input type="checkbox"/> T2460GTE | <input type="checkbox"/> T3060GTE | <input type="checkbox"/> T3672GTE | <input type="checkbox"/> T4884GTE |
| <input type="checkbox"/> T2472GTE | <input type="checkbox"/> T3072GTE | <input type="checkbox"/> T3684GTE | <input type="checkbox"/> T4896GTE |
| <input type="checkbox"/> T2484GTE | <input type="checkbox"/> T3084GTE | <input type="checkbox"/> T3696GTE | <input type="checkbox"/> T48108GTE |
| <input type="checkbox"/> T2496GTE | <input type="checkbox"/> T3096GTE | <input type="checkbox"/> T36108GTE | <input type="checkbox"/> T48120GTE |
| <input type="checkbox"/> T24108GTE | <input type="checkbox"/> T30108GTE | <input type="checkbox"/> T36120GTE | <input type="checkbox"/> T48132GTE |
| <input type="checkbox"/> T24120GTE | <input type="checkbox"/> T30120GTE | <input type="checkbox"/> T36132GTE | <input type="checkbox"/> T48144GTE |
| <input type="checkbox"/> T24132GTE | | | |

Tabletop

- Patented uni-lok® gusset system (patent #5,165,349): gussets are recessed into hat channel, reducing lateral movement.
- Top reinforced with welded-on hat channel.
- Sound-deadened between top and channels.
- 1½" (38mm)-diameter 180° rolled edges on front and rear. Ends are turned down 90° providing for flush installations when required.
- 14 gauge 300 series polished stainless steel.

Crossbracing—1¼" (38mm)-diameter

- Heavy gauge, galvanized.
- Aluminum castings join crossbraces, legs and rear brace.

Legs—1½" (41mm)-diameter

- 24" to 36" (610 to 914mm)-wide units that are 96" (2438mm) and longer come with six legs or more. 48" (1219mm)-wide units that are 72" (1829mm) and longer come with six legs or more.
- Heavy gauge galvanized steel.
- 1" (25mm) adjustable hi-impact plastic feet.

Options / Accessories

- | | |
|--|---|
| <input type="checkbox"/> Drawer | <input type="checkbox"/> Duplex receptacles |
| <input type="checkbox"/> Lock | <input type="checkbox"/> Pot rack |
| <input type="checkbox"/> Casters | <input type="checkbox"/> Sink |
| <input type="checkbox"/> Stainless steel bullet feet | <input type="checkbox"/> Stabilizer Bar (for 30" and 36"-wide tables) |
| <input type="checkbox"/> Overshelves | |

EAGLE GROUP
 100 Industrial Boulevard, Clayton, DE 19938-8903 USA
 Phone: 302-653-3000 • 800-441-8440 • Fax: 302-653-2065
www.eaglegrp.com
www.eaglehmc.com

For custom configuration or fabrication needs, contact our **SpecFAB® Division**.
 Phone: 302-653-3000 • Fax: 302-653-2065 • e-mail: quotes@eaglegrp.com



Spec sheets available for viewing, printing or downloading from our online literature library at our websites

Catalog Specification Sheet No. **Eg10.42C** Spec-Master® Series Worktables with Flat Top and Galvanized Tubular Base



Item No.: _____
 Project No.: _____
 S.I.S. No.: _____

Worktables with Flat Top and Galvanized Tubular Base —Spec-Master® Series

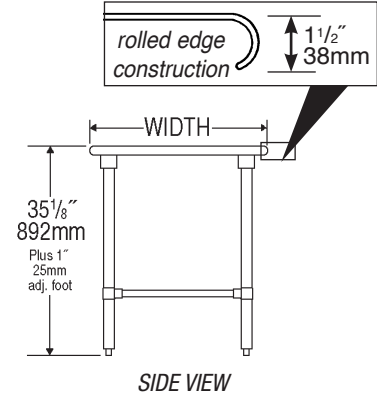
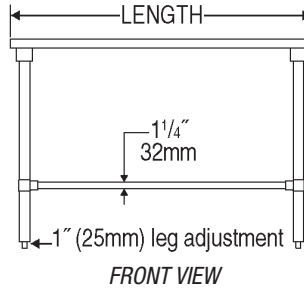
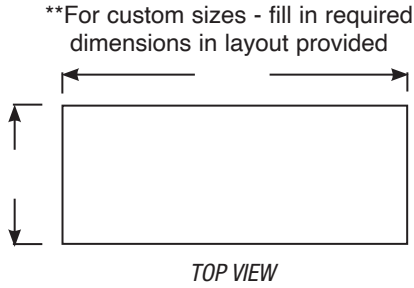

model #	# of legs	width		length		weight	
		in.	mm	in.	mm	lbs.	kg
T2424GTE	4	24"	610	24"	610	44	20.0
T2430GTE	4	24"	610	30"	762	51	23.1
T2436GTE	4	24"	610	36"	914	53	24.0
T2448GTE	4	24"	610	48"	1219	67	30.4
T2460GTE	4	24"	610	60"	1524	79	35.8
T2472GTE	4	24"	610	72"	1829	82	37.2
T2484GTE	4	24"	610	84"	2134	132	59.9
T2496GTE	6	24"	610	96"	2438	157	71.2
T24108GTE	6	24"	610	108"	2743	160	72.6
T24120GTE	6	24"	610	120"	3048	165	74.8
T24132GTE	8	24"	610	132"	3353	199	90.3
T24144GTE	8	24"	610	144"	3658	234	106.6
T3030GTE	4	30"	762	30"	762	55	25.0
T3036GTE	4	30"	762	36"	914	62	28.1
T3048GTE	4	30"	762	48"	1219	77	34.9
T3060GTE	4	30"	762	60"	1524	87	39.5
T3072GTE	4	30"	762	72"	1829	105	47.6
T3084GTE	4	30"	762	84"	2134	137	62.1
T3096GTE	6	30"	762	96"	2438	169	76.7
T30108GTE	6	30"	762	108"	2743	176	79.8
T30120GTE	6	30"	762	120"	3048	182	82.6
T30132GTE	8	30"	762	132"	3353	210	95.3
T30144GTE	8	30"	762	144"	3658	239	108.4
T3648GTE	4	36"	914	48"	1219	84	38.1
T3660GTE	4	36"	914	60"	1524	99	44.9
T3672GTE	4	36"	914	72"	1829	114	51.7
T3684GTE	4	36"	914	84"	2134	183	83.0
T3696GTE	6	36"	914	96"	2438	203	92.1
T36108GTE	6	36"	914	108"	2743	210	95.3
T36120GTE	6	36"	914	120"	3048	217	98.4
T36132GTE	8	36"	914	132"	3353	229	103.9
T36144GTE	8	36"	914	144"	3658	241	109.3
T4848GTE	4	48"	1219	48"	1219	147	66.7
T4860GTE	4	48"	1219	60"	1524	162	73.5
T4872GTE	6	48"	1219	72"	1829	182	82.6
T4884GTE	8	48"	1219	84"	2134	197	89.4
T4896GTE	8	48"	1219	96"	2438	241	109.3
T48108GTE	8	48"	1219	108"	2743	278	126.1
T48120GTE	8	48"	1219	120"	3048	316	143.3
T48132GTE	8	48"	1219	132"	3353	347	157.4
T48144GTE	8	48"	1219	144"	3658	379	171.9

EAGLE GROUP
 100 Industrial Boulevard, Clayton, DE 19938-8903 USA
 Phone: 302-653-3000 or 800-441-8440 • Fax: 302-653-2065
 www.eaglegrp.com • www.eaglehmc.com

Printed in U.S.A.
 ©2024 by Eagle Group

Rev. 08/24

Spec sheets available for viewing, printing or downloading from our online literature library at our websites

Although every attempt has been made to ensure the accuracy of the information provided, we cannot be held responsible for typographical or printing errors. Information and specifications are subject to change without notice. Please confirm at time of order.