

THE CLEAR CHOICE

Spec-SHIELD® Food Guards

The unique design of Eagle's Spec-SHIELD® Adjustable Food Guards, allows you to easily adjust the height and angle of the glass panels (without the use of tools) to best match your service style. SpecShield® has no holes in the glass panels, allowing for flexibility in mounting locations, making installation simpler and allowing for easy adjustments in the field.

Available as self service and cafeteria configurations, SpecShield® food shields bring another unique Eagle advantage to our product offering and offer you a clear benefit over others in the marketplace.

Spec-SHIELD® - Innovative Design, Easy Adjustability and Simpler Installs .. Another Eagle Advantage..

Scan to
Watch
Video

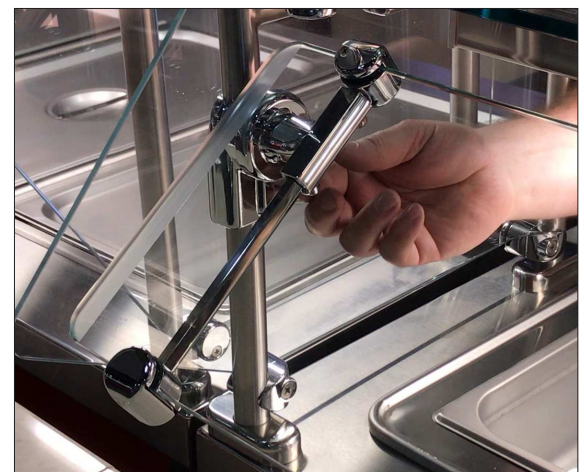

**UNIQUE PATENTED
DESIGN - 3 PATENTS**

Patent Nos. 9,538,868; 9,516,958;
9,339,131; 9,326,621; 9,723,935



Profit from the Eagle Advantage®

What is Spec-SHIELD®

Eagle's Spec-SHIELD® is an innovative, fully-adjustable sneeze guard / counter protector system. Glass is held in place with patented-design casting that allows for ease of glass adjustment as well as easy removal for cleaning. Angle of front glass adjusts in 18° increments, allowing for acceptance by local health codes as well as meeting NSF requirements.



UNIQUE PATENTED DESIGN = 3 PATENTS

Patent Nos. 9,538,868; 9,516,958; 9,339,131;
9,326,621; 9,723,935

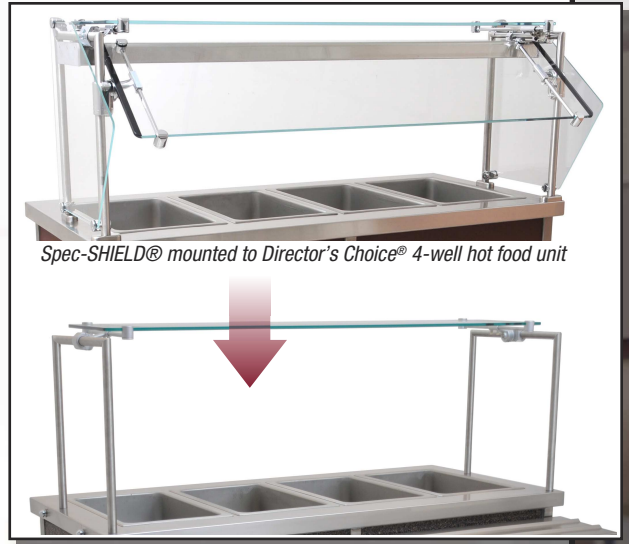

Spec-SHIELD® mounted to Director's Choice® 4-well hot food unit

How it works...

Pull knob for angle adjustment of panels

Angle adjusts in 18° increments.

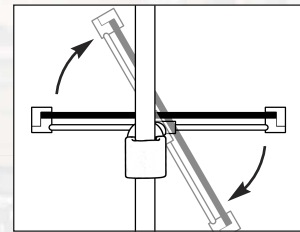

Split casting for removal or adjustment

Loosen set screws to separate split casting, allowing for removal of entire sneeze guard assembly and adjustment of height.

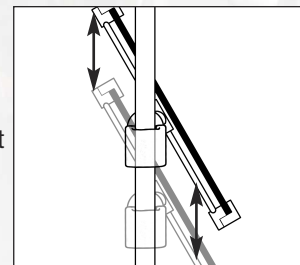

Set screws for adjustment of panels

When loosened, adjacent rod can slide freely inside the housing, allowing for movement of panel without the need to move or take apart the split casting.

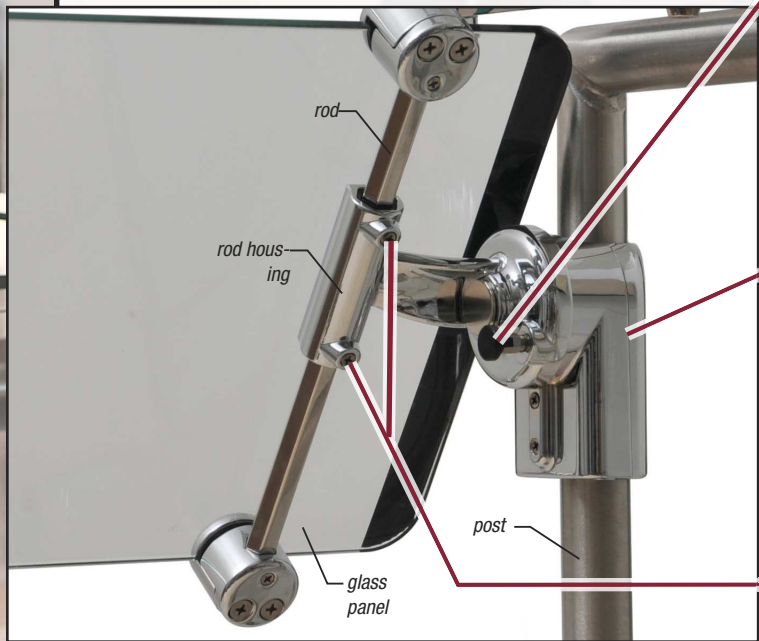
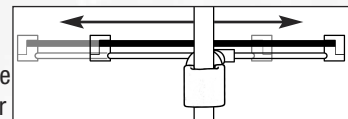

In addition to our website, Spec-SHIELD® can be found in the following libraries:



Kochman Consultants, Ltd.



AutoQuotes



100 Industrial Boulevard, Clayton, DE 19938-8903 USA • Phone: 302-653-3000 • Fax: 302-653-2065

www.eaglegrp.com • www.eaglegrpnews.com

For custom configuration or fabrication needs, contact our SpecFAB® Division. P: 302-653-3000 • F: 302-653-2065 • e-mail: quotes@eaglegrp.com

Spec-SHIELD® Self-Service Food Guards

Self-service food shield designed to meet NSF requirements. Front allows maximum customer access to the food product while maximizing protection. Rear allows full access by the kitchen staff for replenishing product. Available in single or double tier models.

Single-Tier Units

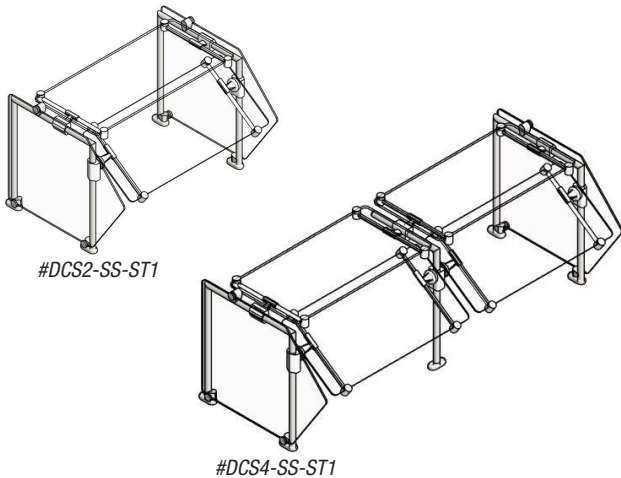

Double-Tier Units

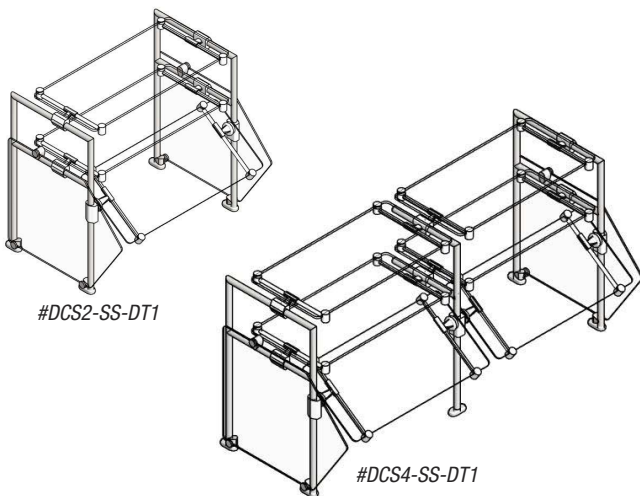

MODELS:

- DCS2-SS-ST1
- DCS3-SS-ST1
- DCS4-SS-ST1
- DCS4-SS-ST1-NC
- DCS5-SS-ST1
- DCS6-SS-ST1
- DCS2-SS-DT1
- DCS3-SS-DT1
- DCS4-SS-DT1
- DCS4-SS-DT1-NC
- DCS5-SS-DT1
- DCS6-SS-DT1

Design and Construction Features

- No holes in glass panels allows for flexibility in mounting locations
- Front glass is adjustable vertically and may be rotated on 18° increments
- Top glass is adjustable horizontally.
- 1" stainless steel posts
- Mounting plates are cast aluminum with stainless steel covers
- Die cast aluminum with chrome finish brackets
- 3/4" radius corners on all glass panels
- Top glass is 3/8" thick
- Front glass is 1/4" thick. Optional 3/8"-thick front glass required for spans over 54"
- End glass included

Options / Accessories

- Heat lamps
- Lights
- 3 5/8" round mounting plate
- 3" Oval mounting plate
- 3" Oval offset mounting plate
- 2" x 8" rectangular mounting plate
- 3-point anchor
- Custom lengths available

Go to next page
for dimensions



100 Industrial Boulevard, Clayton, DE 19938-8903 USA • Phone: 302-653-3000 • Fax: 302-653-2065

www.eaglegrp.com

For custom configuration or fabrication needs, contact our SpecFAB® Division. P: 302-653-3000 • F: 302-653-2065 • e-mail: quotes@eaglegrp.com

Spec-SHIELD® Self-Service Food Guards

Single-Tier

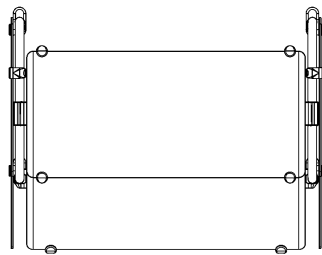

TOP VIEW

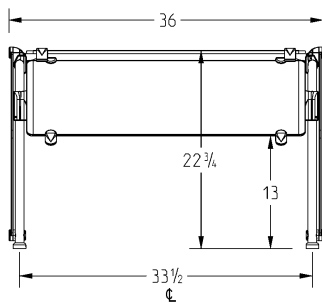

FRONT VIEW

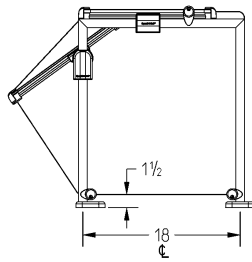

SIDE VIEW

(model #DCS2-SS-ST1 shown)

Double-Tier

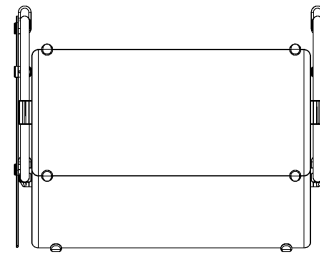

TOP VIEW

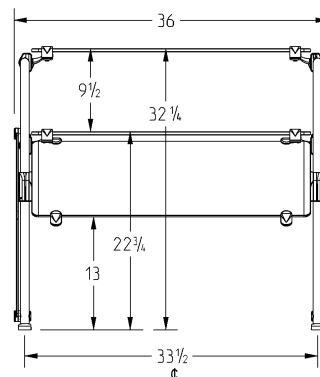

FRONT VIEW

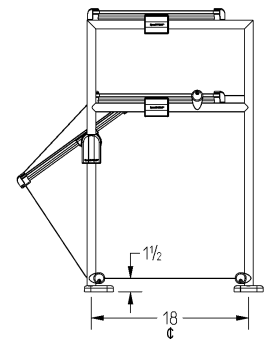

SIDE VIEW

(model #DCS2-SS-DT1 shown)

(note: 36-inch models shown)

fits Series	# of leg assemblies	length		Single-Tier	Double-Tier
		in.	mm	model #	model #
DCS2	2	36"	914	DCS2-SS-ST1	DCS2-SS-DT1
DCS3	2	50"	1270	DCS3-SS-ST1	DCS3-SS-DT1
DCS4	2	64"	1626	DCS4-SS-ST1-NC*	DCS4-SS-DT1-NC*
DCS4	3	64"	1626	DCS4-SS-ST1**	DCS4-SS-DT1**
DCS5	3	78"	1981	DCS5-SS-ST1**	DCS5-SS-DT1**
DCS6	3	96"	2438	DCS6-SS-ST1**	DCS6-SS-DT1**

* Front and top glass are 3/8" thick.
 ** Unit comes with mid support post.



100 Industrial Boulevard, Clayton, DE 19938-8903 USA • Phone: 302-653-3000 • Fax: 302-653-2065
www.eaglegrp.com

For custom configuration or fabrication needs, contact our SpecFAB® Division. P: 302-653-3000 • F: 302-653-2065 • e-mail: quotes@eaglegrp.com

Spec-SHIELD® Self-Service Buffet Food Guards

Self-service buffet food shield designed to meet NSF requirements. Front and rear allow maximum customer access to the food product while maximizing protection. Available in single- or double-tier models.

Single-Tier Units

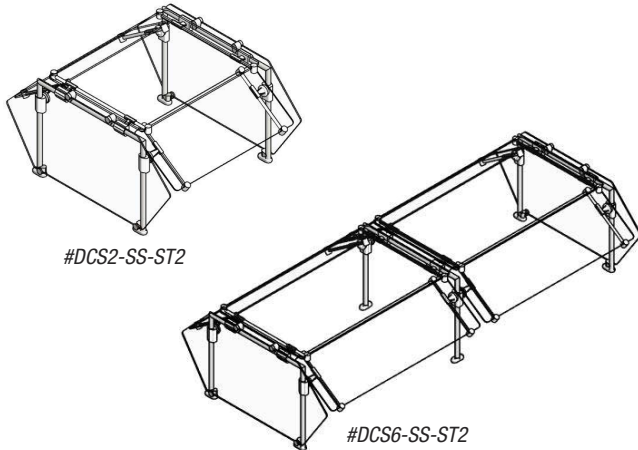

Double-Tier Units

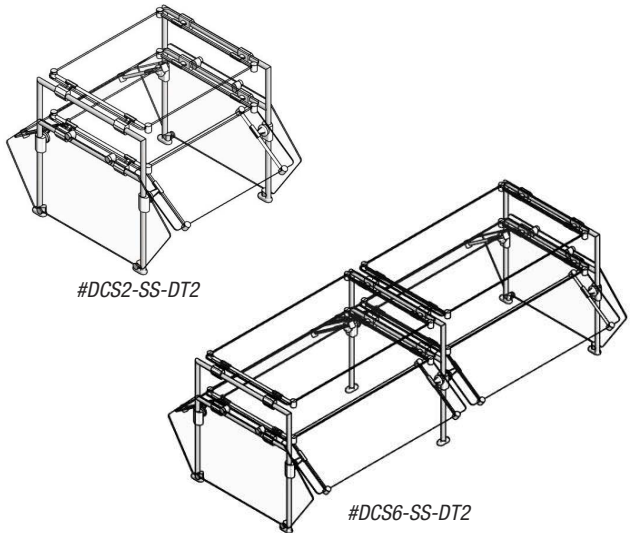

MODELS:

- DCS2-SS-ST2
- DCS3-SS-ST2
- DCS4-SS-ST2
- DCS4-SS-ST2-NC
- DCS5-SS-ST2
- DCS6-SS-ST2
- DCS2-SS-DT2
- DCS3-SS-DT2
- DCS4-SS-DT2
- DCS4-SS-DT2-NC
- DCS5-SS-DT2
- DCS6-SS-DT2

Design and Construction Features

- No holes in glass panels allows for flexibility in mounting locations
- Front glass is adjustable vertically and may be rotated on 18° increments
- Top glass is adjustable horizontally.
- 1" stainless steel posts
- Mounting plates are cast aluminum with stainless steel covers
- Die cast aluminum with chrome finish brackets
- 3/4" radius corners on all glass panels
- Top glass is 3/8" thick
- Front glass is 1/4" thick. Optional 3/8"-thick front glass required for spans over 54"
- End glass included

Options / Accessories

- Heat lamps
- Lights
- 3 5/8" round mounting plate
- 3" Oval mounting plate
- 3" Oval offset mounting plate
- 2" x 8" rectangular mounting plate
- 3-point anchor
- Custom lengths available

Go to next page
for dimensions



100 Industrial Boulevard, Clayton, DE 19938-8903 USA • Phone: 302-653-3000 • Fax: 302-653-2065

www.eaglegrp.com

For custom configuration or fabrication needs, contact our SpecFAB® Division. P: 302-653-3000 • F: 302-653-2065 • e-mail: quotes@eaglegrp.com

Spec-SHIELD® Self-Service Buffet Food Guards

Single-Tier

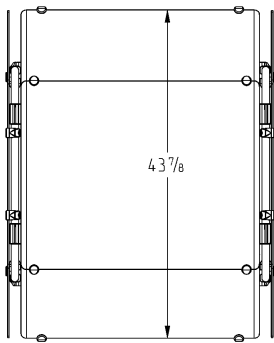

TOP VIEW

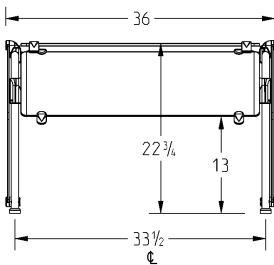

FRONT VIEW

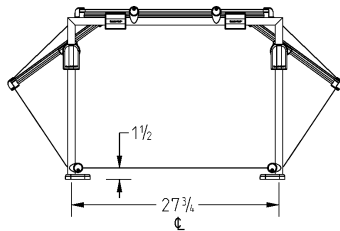

SIDE VIEW

(model #DCS2-SS-ST2 shown)

Double-Tier

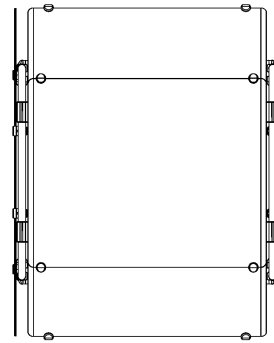

TOP VIEW

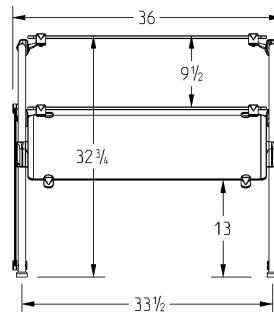

FRONT VIEW

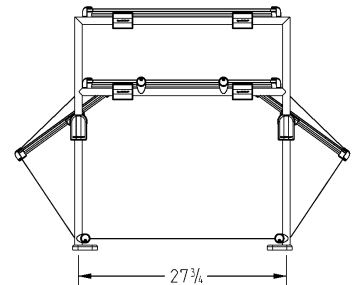

SIDE VIEW

(model #DCS2-SS-DT2 shown)

(note: 36-inch models shown)

fits Series	# of leg assemblies	length		Single-Tier	Double-Tier
		in.	mm	model #	model #
DCS2	2	36"	914	DCS2-SS-ST2	DCS2-SS-DT2
DCS3	2	50"	1270	DCS3-SS-ST2	DCS3-SS-DT2
DCS4	2	64"	1626	DCS4-SS-ST2-NC*	DCS4-SS-DT2-NC*
DCS4	3	64"	1626	DCS4-SS-ST2**	DCS4-SS-DT2**
DCS5	3	78"	1981	DCS5-SS-ST2**	DCS5-SS-DT2**
DCS6	3	96"	2438	DCS6-SS-ST2**	DCS6-SS-DT2**

* Front and top glass are 3/8" thick.

** Unit comes with mid support post.



100 Industrial Boulevard, Clayton, DE 19938-8903 USA • Phone: 302-653-3000 • Fax: 302-653-2065

www.eaglegrp.com

For custom configuration or fabrication needs, contact our SpecFAB® Division. P: 302-653-3000 • F: 302-653-2065 • e-mail: quotes@eaglegrp.com

Spec-SHIELD® Cafeteria Food Guards

Cafeteria food shield designed to meet NSF requirements. Front allows maximum customer view of the food product while maximizing protection. Rear allows full access by the kitchen staff for replenishing product. Available in single- or double-tier models.

with Glass Top

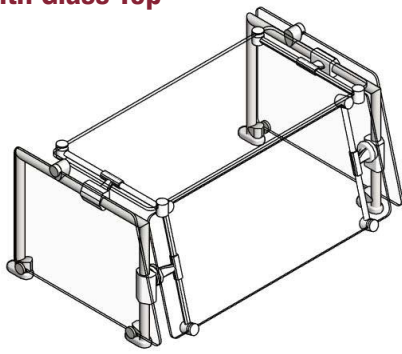

#DCS2-CF-GT

with Solid Top

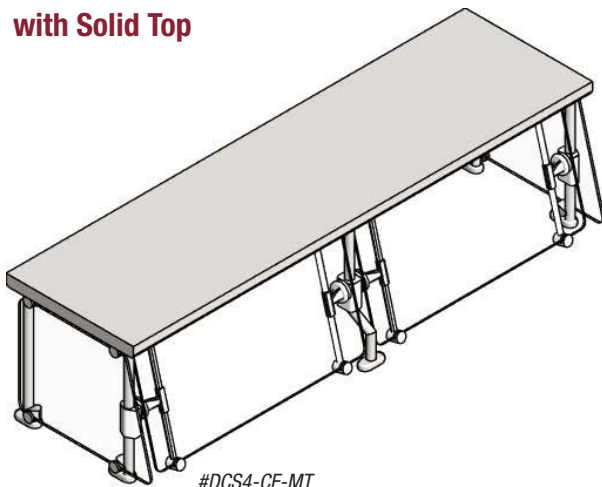

#DCS4-CF-MT

MODELS:

- DCS2-CF-GT
- DCS3-CF-GT
- DCS4-CF-GT
- DCS4-CF-GT-NC
- DCS5-CF-GT
- DCS6-CF-GT
- DCS2-CF-MT
- DCS3-CF-MT
- DCS4-CF-MT
- DCS4-CF-MT-NC
- DCS5-CF-MT
- DCS6-CF-MT

Design and Construction Features

- No holes in glass panels allows for flexibility in mounting locations
- Front glass is adjustable vertically and may be rotated on 18° increments
- Top glass is adjustable horizontally.
- 1" stainless steel posts
- Mounting plates are cast aluminum with stainless steel covers
- Die cast aluminum with chrome finish brackets
- 3/4" radius corners on all glass panels
- Top glass (on models with glass top) is 3/8" thick
- Front glass is 1/4" thick. Optional 3/8"-thick front glass required for spans over 54"
- End glass included

Options / Accessories

- Heat lamps
- Lights
- 3 5/8" round mounting plate
- 3" Oval mounting plate
- 3" Oval offset mounting plate
- 2" x 8" rectangular mounting plate
- 3-point anchor
- Custom lengths available

Go to next page
for dimensions



100 Industrial Boulevard, Clayton, DE 19938-8903 USA • Phone: 302-653-3000 • Fax: 302-653-2065

www.eaglegrp.com

For custom configuration or fabrication needs, contact our SpecFAB® Division. P: 302-653-3000 • F: 302-653-2065 • e-mail: quotes@eaglegrp.com

Spec-SHIELD® Cafeteria Food Guards

...with Glass Top

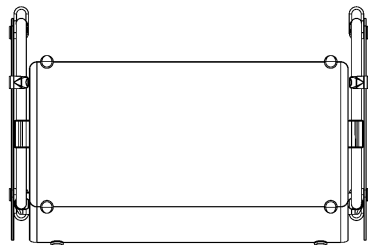

TOP VIEW

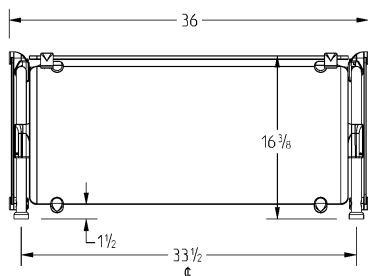

FRONT VIEW

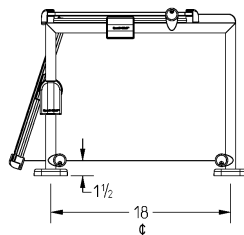

SIDE VIEW

...or with Solid Top

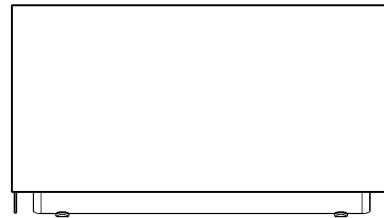

TOP VIEW

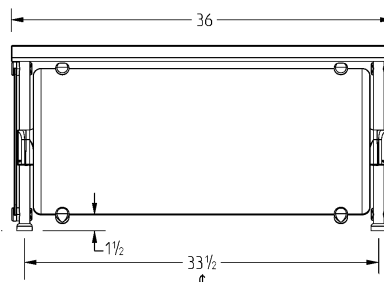

FRONT VIEW

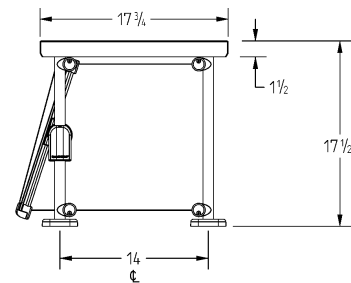

SIDE VIEW

(note: 36-inch models shown)

fits Series	# of leg assemblies	length		with Glass Top		with Solid Top	
		in.	mm	model #	model #		
DCS2	2	36"	914	DCS2-CF-GT	DCS2-CF-MT		
DCS3	2	50"	1270	DCS3-CF-GT	DCS3-CF-MT		
DCS4	2	64"	1626	DCS4-CF-GT-NC*	DCS4-CF-MT-NC*		
DCS4	3	64"	1626	DCS4-CF-GT**	DCS4-CF-MT**		
DCS5	3	78"	1981	DCS5-CF-GT**	DCS5-CF-MT**		
DCS6	3	96"	2438	DCS6-CF-GT**	DCS6-CF-MT**		

* Front and top glass are 3/8" thick.
** Unit comes with mid support post.



100 Industrial Boulevard, Clayton, DE 19938-8903 USA • Phone: 302-653-3000 • Fax: 302-653-2065

www.eaglegrp.com

For custom configuration or fabrication needs, contact our SpecFAB® Division. P: 302-653-3000 • F: 302-653-2065 • e-mail: quotes@eaglegrp.com

Spec-SHIELD® Cafeteria Carving Station Food Guards

Carving station food shield designed to meet NSF requirements. Carving station allows the customer to view product as it is being prepared, plated, carved, or displayed.

MODELS:

- DCS2-CF-NT
- DCS3-CF-NT
- DCS4-CF-NT
- DCS4-CF-NT-NC
- DCS5-CF-NT
- DCS6-CF-NT

Design and Construction Features

- No holes in glass panels allows for flexibility in mounting locations
- Front glass is adjustable vertically and may be rotated on 18° increments
- 1" stainless steel posts
- Mounting plates are cast aluminum with stainless steel covers
- Die cast aluminum with chrome finish brackets
- 3/4" radius corners on all glass panels
- Front glass is 1/4" thick. Optional 3/8"-thick front glass required for spans over 54"
- End glass included

Options / Accessories

- Heat lamps
- Lights
- 3 5/8" round mounting plate
- 3" Oval mounting plate
- 3" Oval offset mounting plate
- 2" x 8" rectangular mounting plate
- 3-point anchor
- Custom lengths available

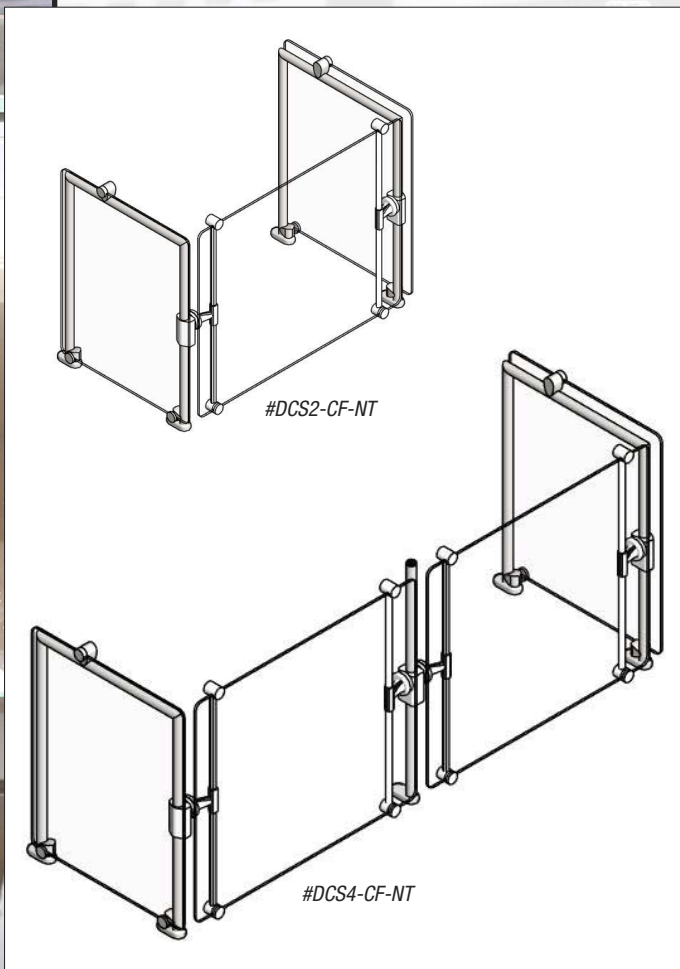

Go to next page
for dimensions



100 Industrial Boulevard, Clayton, DE 19938-8903 USA • Phone: 302-653-3000 • Fax: 302-653-2065

www.eaglegrp.com

For custom configuration or fabrication needs, contact our SpecFAB® Division. P: 302-653-3000 • F: 302-653-2065 • e-mail: quotes@eaglegrp.com

Spec-SHIELD® Cafeteria Carving Station Food Guards

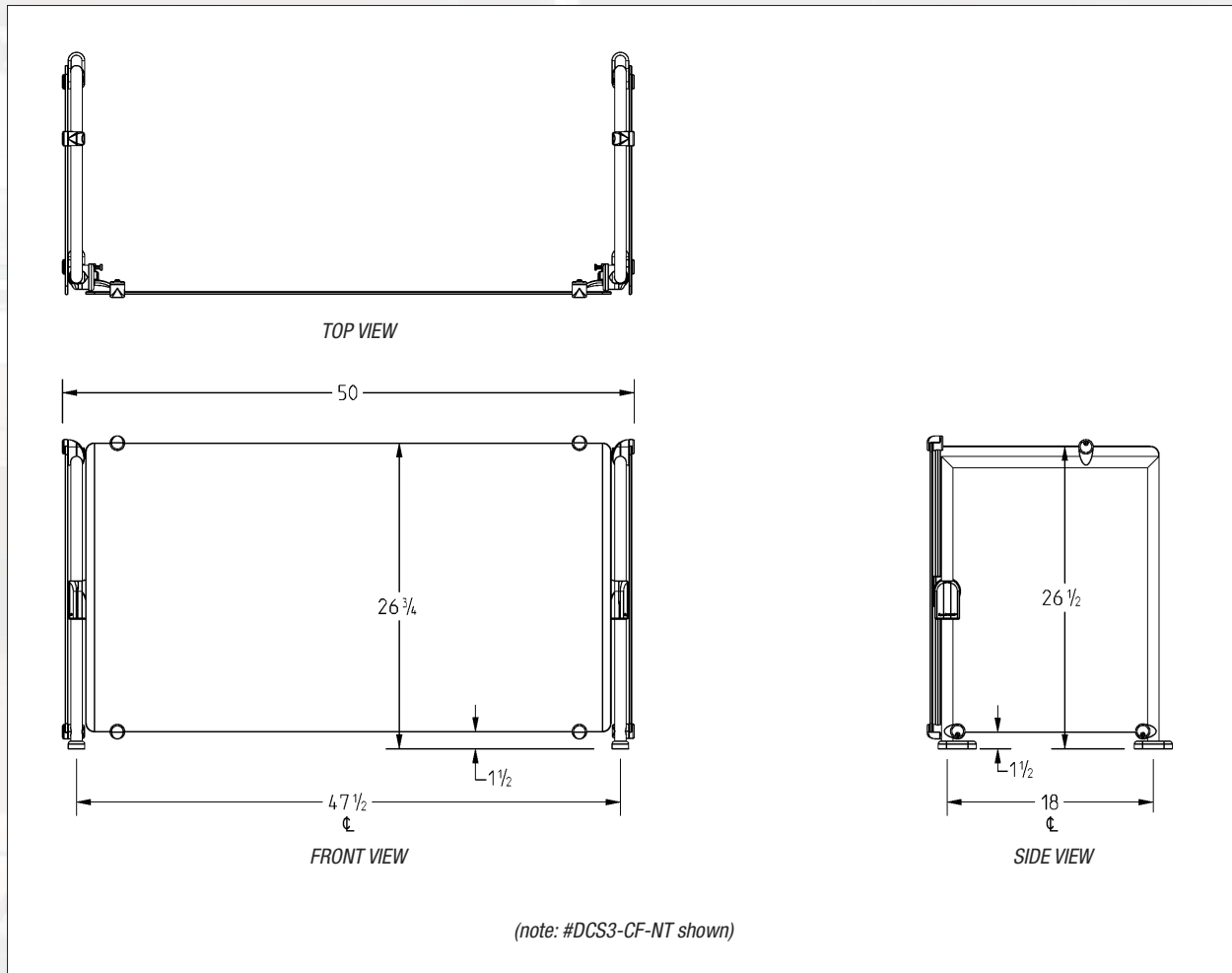

fits Series	# of leg assemblies	length		model #
		in.	mm	
DCS2	2	36"	914	<i>DCS2-CF-NT</i>
DCS3	2	50"	1270	<i>DCS3-CF-NT</i>
DCS4	2	64"	1626	<i>DCS4-CF-NT-NC*</i>
DCS4	3	64"	1626	<i>DCS4-CF-NT**</i>
DCS5	3	78"	1981	<i>DCS5-CF-NT**</i>
DCS6	3	96"	2438	<i>DCS6-CF-NT**</i>

* Front and top glass are 3/8" thick.
 ** Unit comes with mid support post.



100 Industrial Boulevard, Clayton, DE 19938-8903 USA • Phone: 302-653-3000 • Fax: 302-653-2065

www.eaglegrp.com

For custom configuration or fabrication needs, contact our **SpecFAB®** Division. P: 302-653-3000 • F: 302-653-2065 • e-mail: quotes@eaglegrp.com

Spec-SHIELD® Self-Service Food Guards — “Long Span”

Designed to meet NSF requirements. Front allows maximum customer access to the food product while maximizing protection. Rear allows full access by the kitchen staff for replenishing product. Single-tier and double-tier models available in lengths up to 168”.

One-Sided

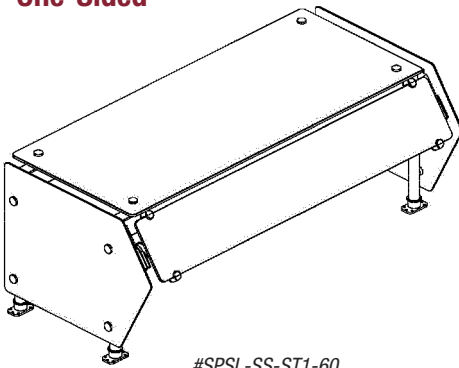

#SPSL-SS-ST1-60

Two-Sided

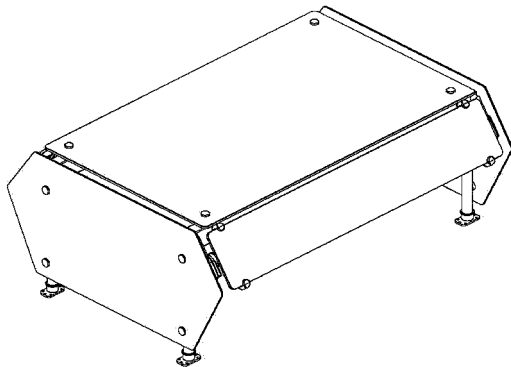

#SPSL-SS-ST2-60

MODELS:

<i>SPSL-SS-ST1-60</i>	<i>SPSL-SS-ST2-60</i>
<i>SPSL-SS-ST1-72</i>	<i>SPSL-SS-ST2-72</i>
<i>SPSL-SS-ST1-84</i>	<i>SPSL-SS-ST2-84</i>
<i>SPSL-SS-ST1-96</i>	<i>SPSL-SS-ST2-96</i>
<i>SPSL-SS-ST1-108</i>	<i>SPSL-SS-ST2-108</i>
<i>SPSL-SS-ST1-120</i>	<i>SPSL-SS-ST2-120</i>
<i>SPSL-SS-ST1-132</i>	<i>SPSL-SS-ST2-132</i>
<i>SPSL-SS-ST1-144</i>	<i>SPSL-SS-ST2-144</i>
<i>SPSL-SS-ST1-156</i>	<i>SPSL-SS-ST2-156</i>
<i>SPSL-SS-ST1-168</i>	<i>SPSL-SS-ST2-168</i>

Design and Construction Features

- Front glass is adjustable vertically and may be rotated on 18” increments
- 1½” stainless steel posts
- Die cast aluminum with chrome finish brackets
- ¾” radius corners on all glass panels
- Glass is ¾” thick
- End glass included

Options / Accessories

- Heat lamps
- Lights
- Custom lengths available

Go to next page
for dimensions



100 Industrial Boulevard, Clayton, DE 19938-8903 USA • Phone: 302-653-3000 • Fax: 302-653-2065

www.eaglegrp.com

For custom configuration or fabrication needs, contact our **SpecFAB®** Division. P: 302-653-3000 • F: 302-653-2065 • e-mail: quotes@eaglegrp.com

Spec-SHIELD® Self-Service Food Guards—“Long Span”

One-Sided

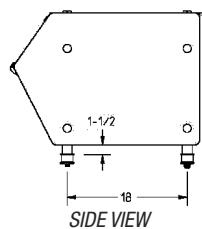
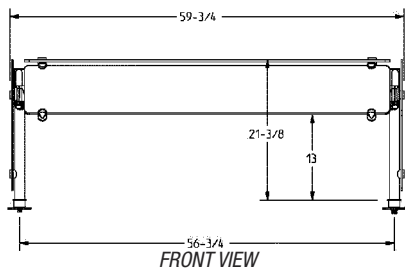
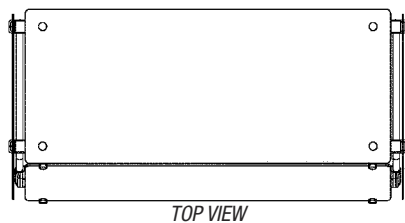

Two-Sided

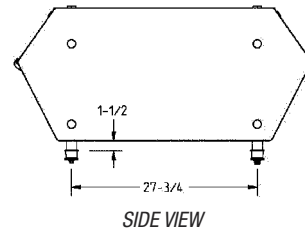
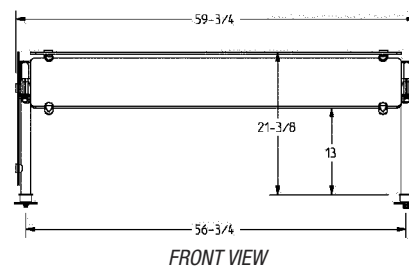
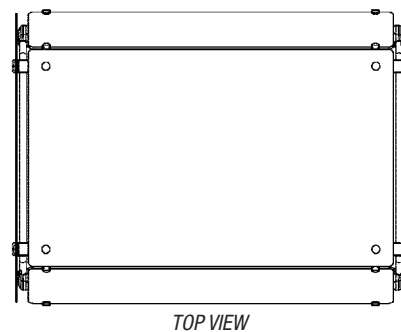

(note: 60-inch models shown)

length		ONE-SIDED	TWO-SIDED
in.	mm	model #	model #
60"	1524	<i>SPSL-SS-ST1-60</i>	<i>SPSL-SS-ST2-60</i>
72"	1829	<i>SPSL-SS-ST1-72</i>	<i>SPSL-SS-ST2-72</i>
84"	2134	<i>SPSL-SS-ST1-84</i>	<i>SPSL-SS-ST2-84</i>
96"	2438	<i>SPSL-SS-ST1-96</i>	<i>SPSL-SS-ST2-96</i>
108"	2743	<i>SPSL-SS-ST1-108</i>	<i>SPSL-SS-ST2-108</i>
120"	3048	<i>SPSL-SS-ST1-120</i>	<i>SPSL-SS-ST2-120</i>
132"	3353	<i>SPSL-SS-ST1-132</i>	<i>SPSL-SS-ST2-132</i>
144"	3658	<i>SPSL-SS-ST1-144</i>	<i>SPSL-SS-ST2-144</i>
156"	3962	<i>SPSL-SS-ST1-156</i>	<i>SPSL-SS-ST2-156</i>
168"	4267	<i>SPSL-SS-ST1-168</i>	<i>SPSL-SS-ST2-168</i>



100 Industrial Boulevard, Clayton, DE 19938-8903 USA • Phone: 302-653-3000 • Fax: 302-653-2065

www.eaglegrp.com

For custom configuration or fabrication needs, contact our SpecFAB® Division. P: 302-653-3000 • F: 302-653-2065 • e-mail: quotes@eaglegrp.com

Portable Spec-SHIELD® Protective Systems

Spec-SHIELD® can now be applied to any pre-existing countertop and/or cabinetry without any permanent alterations. Features 15" polycarbonate front panel mounted on 1" diameter stainless steel post with patented Spec-SHIELD® system. 2"-wide stainless flat bar base with reversible mounting.

MODELS:

SPSH-PFS-SS-24 *SPSH-PFS-SS-54*
SPSH-PFS-SS-30 *SPSH-PFS-SS-60*
SPSH-PFS-SS-36 *SPSH-PFS-SS-66*
SPSH-PFS-SS-42 *SPSH-PFS-SS-72*
SPSH-PFS-SS-48

One-Sided

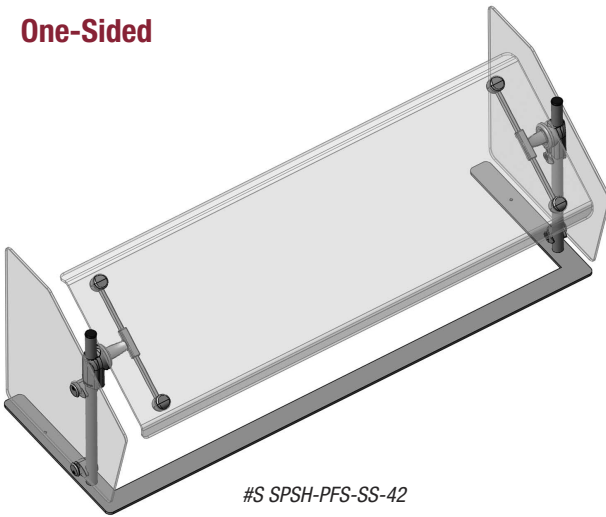

#S SPSH-PFS-SS-42

Design and Construction Features

- Spec-SHIELD® patented adjustability
- 15"-wide ¼"-thick polycarbonate panel
- 1"-diameter stainless steel posts
- 2" stainless steel flat bar base
- Reversible mounting

Options / Accessories

- End panels*
- Custom lengths available

* End panels required to meet NSF compliance unless the end of the unit is within 3" of the building structure.

Go to next page
for dimensions



100 Industrial Boulevard, Clayton, DE 19938-8903 USA • Phone: 302-653-3000 • Fax: 302-653-2065

www.eaglegrp.com

For custom configuration or fabrication needs, contact our **SpecFAB® Division**. P: 302-653-3000 • F: 302-653-2065 • e-mail: quotes@eaglegrp.com

Portable Spec-SHIELD® Protective Systems

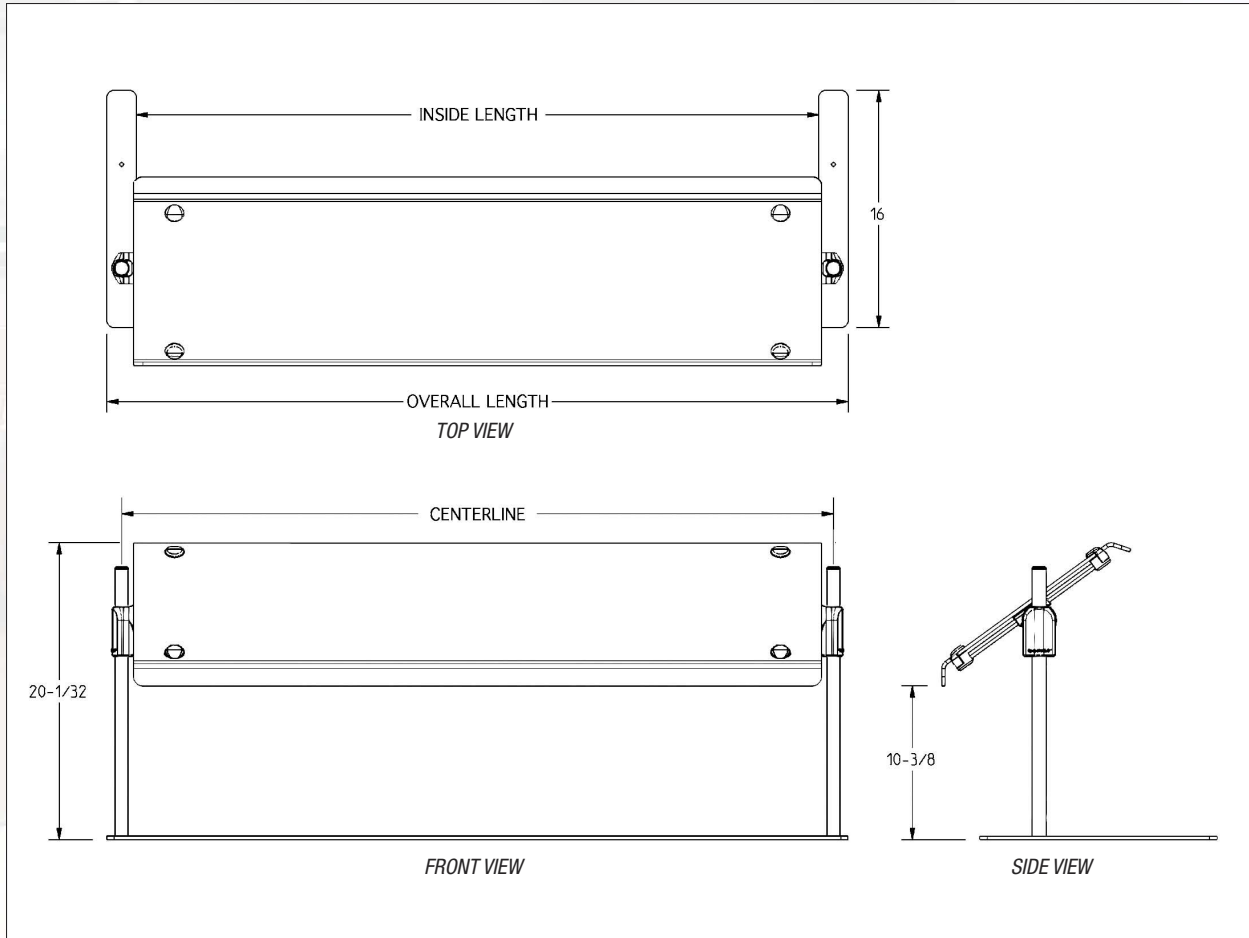

O.A. length*		inside length		centerline		model #
in.	mm	in.	mm	in.	mm	
26"	660	22"	559	24"	610	SPSH-PFS-SS-24
32"	813	28"	660	30"	762	SPSH-PFS-SS-30
38"	965	34"	864	36"	914	SPSH-PFS-SS-36
44"	1118	40"	1016	42"	1067	SPSH-PFS-SS-42
50"	1270	46"	1168	48"	1219	SPSH-PFS-SS-48
56"	1422	52"	1321	54"	1372	SPSH-PFS-SS-54
62"	1575	58"	1473	60"	1524	SPSH-PFS-SS-60
68"	1727	64"	1626	66"	1676	SPSH-PFS-SS-66
74"	1880	70"	1778	72"	1829	SPSH-PFS-SS-72

* End glass adds 1/2" to overall dimension.



100 Industrial Boulevard, Clayton, DE 19938-8903 USA • Phone: 302-653-3000 • Fax: 302-653-2065

www.eaglegrp.com

For custom configuration or fabrication needs, contact our **SpecFAB®** Division. P: 302-653-3000 • F: 302-653-2065 • e-mail: quotes@eaglegrp.com

DIRECTOR'S CHOICE®

Custom Signage
and Decal Service

Autodesk®
Building Design Suite
Premium

Eagle can use Revit® software to provide a rendered proof for final approval before production.

Contact us:
revit@eaglegrp.com | 800-441-8440

Customize IT



Equipment that Makes a Statement

• LASER-CUTTING & ETCHING

- Offers a “high-tech” look
- Creates smooth curves along text/artwork

• DECALS

- Industrial strength
- Factory installed
- Vinyl with adhesive backing

• CONTACT US FOR A QUOTE

FAX: 302-653-3091

E-MAIL: quotes@eaglegrp.com

EAGLE OFFERS PERSONALIZED BRANDING!

Eagle offers personalized branding of graphic designs as an option on portable bars, Director's Choice® cafeteria serving units and SpecFAB® custom counters.

Select from stainless steel, various plastics, laminates, solid surface man-made and naturally occurring materials, woods, magnetic sheets

and designer aluminum. We provide a 3D rendering of your logo or design prior to production.

Here's an idea, LIGHT IT UP! Laser etched cast acrylic or multi layer acrylic effects. Lighting options include low voltage LED in single or variable colors. Stainless steel or millwork trim completes the custom look.



100 Industrial Boulevard, Clayton, DE 19938-8903 USA • Phone: 302-653-3000 • Fax: 302-653-2065

www.eaglegrp.com

For custom configuration or fabrication needs, contact our SpecFAB® Division. P: 302-653-3000 • F: 302-653-2065 • e-mail: quotes@eaglegrp.com

Consider Eagle's D.C. Modular Cafeteria Serving Line...



Eagle's Director's Choice® Modular Cafeteria Serving Units are 30" wide and available in three working heights - the standard 34" which complies with ADA guidelines for accessibility standards, 30" for middle schools, and low profile 28" for elementary schools. Each unit is fully mobile on standard 5" casters, two with brakes on server side. The frame and top are constructed of type 304 stainless steel. A docking device keeps adjoining units together without the use of tools. All units come with a standard front laminate panel—holly berry red (Wilsonart® D307-60)—mounted on galvanized subpanel. Many options are available, including decorative laminate or stainless steel end panels and front panels, removable undershelves, rear doors and panels, tray slides, work shelves, and single- or double-tier glass sneeze guards. Custom accessories include decorative deluxe sneeze guards, decorative perimeter skirt and inboard casters.



SpecFAB Division

Quality Stainless & Millwork Fabrication

Eagle's SpecFAB® Division was formed to fill the gap between standard equipment and high-cost, wish-and-wait-for highly customized equipment. SpecFAB® provides a way to short-cut the design and fabrication process. Depending on our customer's need, we can build custom configurations from scratch or we can design from our superior modular components. Having this flexibility means we can deliver custom equipment faster and at a lower cost. There's more that separates SpecFAB® from other custom equipment providers. It is the investment in the most sophisticated manufacturing systems that means each and every custom piece is consistent. We can make multiple pieces with repeat precision, just like standard equipment.

Utilizing AutoQuotes® and SpecQuote® quotation software packages, our quotation department will prepare a custom quotation to meet your individual project needs. Working with the latest AutoCAD® software, Eagle's design staff will prepare submittal drawings for customer approval. These submittal drawings are supplied with quotations as needed. Eagle Group also has the largest catalog entry in the Auto Quotes system with virtually thousands of models to choose.

Please forward quotation requests to: quotes@eaglegrp.com

Custom Equipment Manufactured to Your Specifications!



Profit from the Eagle Advantage®

Foodservice Division:

Phone: (800) 441-8440 • FAX: (302) 653-2065

Corporate Headquarters:

100 Industrial Boulevard • Clayton, DE
19938-8903 USA • Phone: (302) 653-3000

www.eaglegrp.com

www.eaglegrpnews.com

www.eaglemhc.com

