



Profit from the Eagle Advantage®

Foodservice Division: (800) 441-8440

MHC/Retail Display Divisions: (800) 637-5100

FAX: (302) 653-2065

Product Announcement

Short Form Specifications

Eagle Chemical Storage Wall Cabinet, model _____. Available with heavy gauge type 300 or 430 series stainless steel construction, with stainless steel fixed center shelf and top sloped for cleaning. Back is recessed, with concealed mounting plate for installation. Available with left- or right-hinged door, with or without factory-installed door lock. Door is double-panel stainless steel, with magnetic catch, and removable for cleaning. All units are 24" (610mm) end-to-end, 15" (381mm) front-to-back.

Item #:	_____
Model #:	_____
Project #:	_____
SIS #:	_____

EG8092 Rev. 03/18

Design & Construction Features

- Units available with 300 or 430 series stainless steel construction.
- Top is sloped forward to help reduce dust build-up.
- Stationary center shelf features safety edges. Additional shelves can be specified and are factory installed.
- Ends, back and bottom are folded and spot-welded together. All feature safety edges.
- Back is recessed, with full-length concealed mounting plate for easy installation*. "Z"-brackets included.
- Both side panels are vented.
- Cabinets are available left- or right-hinged stainless steel doors, with or without door lock.
- All doors are double-panel and removable for easy cleaning.

* Wall mounting hardware not included.

For custom configuration or fabrication needs, contact our **SpecFAB® Division**.
Phone: (302) 653-3000. FAX: (302) 653-2065.
E-mail: quotes@eaglegrp.com



Chemical Storage Wall Cabinets

with Fixed Center Shelf



model #WCH-24C-LL

Ideal for storing hazardous liquids in a clean environment. The entire unit is constructed of polished heavy gauge stainless steel, with your choice of either 300 or 430 series stainless steel. Safety features include three columns of four 2 5/8"-long vents on both side panels, preventing build-up of potentially dangerous fumes inside the cabinet.

Doors—available left- or right-hinged—feature easy-to-reach full-height recessed handle, double-panel construction, and are removable for cleaning. A full 180° open radius allows for safe loading and unloading. Available with or without factory-installed keyed lock.

These Chemical Storage Wall Cabinets are equipped with one affixed center shelf, allowing for storage of various bottles, drums etc.



Profit from the Eagle Advantage®

Chemical Storage Wall Cabinets

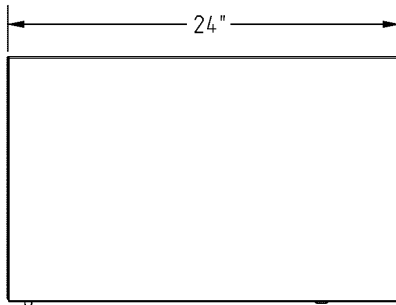

TOP VIEW

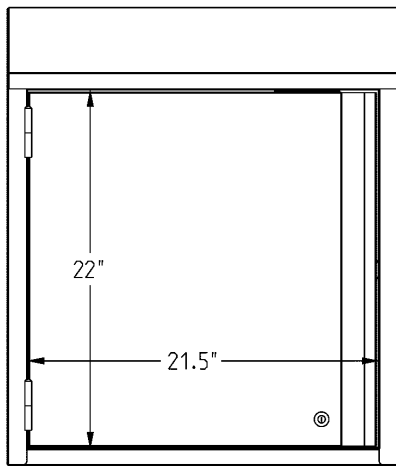

FRONT VIEW

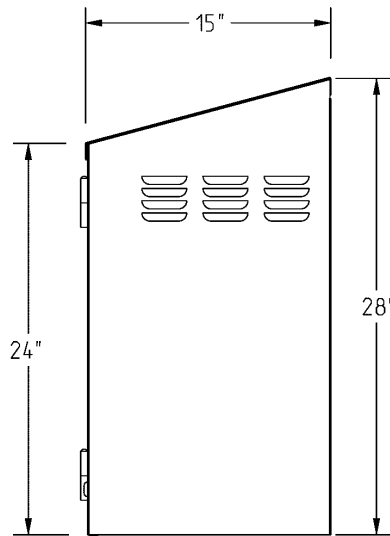

SIDE VIEW

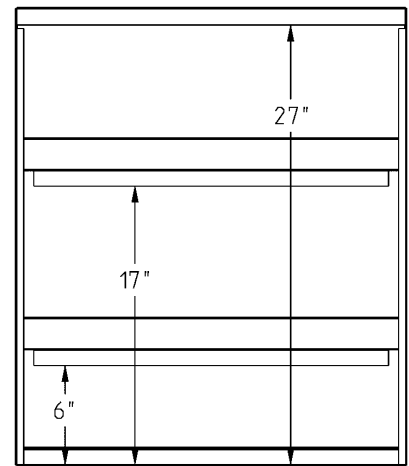

REAR VIEW

(model #WCH-24C-LL shown)

description	length x width		Type 300 model #	Type 430 model #
	in.	mm		
all stainless steel, with left-hinged door	24" x 15"	610 x 381	WCH-24C-L	WCH4-24C-L
all stainless steel, with left-hinged door with key lock	24" x 15"	610 x 381	WCH-24C-LL	WCH4-24C-LL
all stainless steel, with right-hinged door	24" x 15"	610 x 381	WCH-24C-R	WCH4-24C-R
all stainless steel, with right-hinged door with key lock	24" x 15"	610 x 381	WCH-24C-RL	WCH4-24C-RL

Printed in U.S.A.
©2018 by Eagle Group
Rev. 03/18

Foodservice Division: (800) 441-8440 • MHC/Retail Display Division: (800) 637-5100 • Fax: (302) 653-2065 • www.eaglegrp.com

Although every attempt has been made to ensure the accuracy of the information provided, we cannot be held responsible for typographical or printing errors. Information and specifications are subject to change without notice. Please confirm at time of order.