

PART #366759

# Director's Choice® Dish/Cup Dispenser Unit

Retain this manual  
for future reference.

## OPERATIONS MANUAL & INSTRUCTIONS

### CAUTION

INSPECT CONTENTS IMMEDIATELY AND FILE CLAIM WITH DELIVERING CARRIER FOR ANY DAMAGE. **SAVE YOUR BOX AND ALL PACKING MATERIALS.** YOU ARE RESPONSIBLE FOR DAMAGE TO YOUR UNIT IF RETURNED IMPROPERLY PACKED.

### MAINTENANCE



### WARNING



**For Heated Units:** Disconnect unit from power supply prior to cleaning.

Proper cleaning of the unit is required. When rubbing or scouring, always move gently in the direction of the polish lines (grains). A Scotch-Brite™ general purpose pad may be used. **DO NOT USE STEEL WOOL.**

### MAINTENANCE FOR LAMINATES

Laminate surfaces should be cleaned with warm water and mild soaps. Non-abrasive cleaners may also be used. Cleaning products containing bleaching agents should not be used, large quantities of these agents or extended periods of time of exposure to them can cause discoloration.

### CAUTION:

1. This equipment is designed and sold for commercial use only by personnel trained and experienced in its operation and is not sold for consumer use in and around the home nor for use directly by the general public in food service locations.
2. Do not immerse unit in water.
3. All repairs should be done by an authorized service center.
4. Unit should be turned off when not in use. It is recommended that unit be disconnected from power supply by removing plug from receptacle or shutting off power disconnect supply to the unit.

### DOCKING DEVICE

The device comprises of two sub-assemblies: a male bullet catch and a female receiver with a locking plate.

1. Align the units so that the bullet catch and receivers line up.
2. Pull the lever and push the two units together so that the bullet catch is pushed all the way into the receiver.
3. Release the lever and the two units are now securely docked together.
4. To release the two units, pull the lever and slowly push the two units apart. Release the lever and now your units are separate.

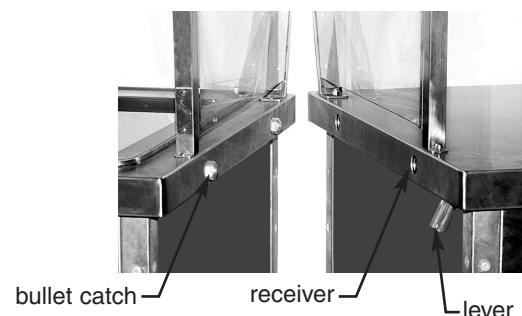

EG10084 Revised 12/07



• 100 Industrial Boulevard, Clayton, Delaware 19938-8903 U.S.A. • [www.eaglegrp.com](http://www.eaglegrp.com)  
• Phone: 302/653-3000 • (Foodservice) 800/441-8440 • (MHC/Retail) 800/637-5100  
• Fax: 302/653-2065

Eagle Foodservice Equipment, Eagle MHC, SpecFAB, and Retail Display are divisions of Eagle Group. ©2007 by the Eagle Group

# Director's Choice® Dish/Cup Dispenser Unit

## SPRING ADJUSTMENT

Adjustables are factory set to an average rate. However, you may need to adjust the springs to obtain best dispensing rate for your dinnerware.

To Adjust for Rate of Rise:

- 1) Lift the tube out of shield.
- 2) Place approximately 4 inches of dinnerware into the tube and note the height of the dinnerware above the tube.
- 3) Load the tube until it is approximately 3/4 full and again note the height of the dinnerware above the tube. If the height is the same as in step 1, the rate is correct.
- 4) If the height is higher than in step 2, unhook one spring from the bottom of the spring hanger and repeat step 2 and 3. Continue disconnecting springs from the bottom hanger until you find the proper spring combination for your dinnerware.

### **NOTE:**

1. It is not necessary to replace the tube in shield to place dinnerware on the tube, leave the shield off until you find the proper adjustment.
2. Balance color and number of springs on all sides of the tube to provide smoothest operation.
3. On unheated tubes, yellow springs are stronger than silver (yellow are rated at 4 ounces and silver are rated at 2½ ounces). On heated tubes, black springs are stronger than gray springs (black are rated at 4 ounces and gray are rated at 2½ ounces).
4. Unit should be operated with legs provided to prevent overheating of surfaces below.
5. Check cord and plug, if provided, appearance for damage, cracking or deterioration. If visible, have replaced by an authorized service agency.

- 5) If the height is lower than in step 2, unhook one spring from the storage bars behind the uprights and hook it onto the moveable head. Again, try to balance colors and number of springs on all sides of tube. Repeat steps 2 and 3 until a consistent dispensing rate is obtained, adding more springs as necessary.

**NOTE:** The wire head must be centered about the spring hanger or the mechanism will bind and not move smoothly to dispense the plates.

## ADJUSTING DISPENSING HEIGHT

Raise or lower the height of the top dish above the tube by connecting or disconnecting springs or replacing a lighter spring with a stronger one or vice-versa.

## TEMPERATURE ADJUSTMENT (HEATED ONLY)

Remove the tube from the shield and adjust the thumbwheel located about 3 inches below the indicator light. Turn wheel up to raise the temperature and down to decrease it.

## ELECTRICAL CONNECTIONS



### WARNING



Check the data plate on unit to determine what voltage unit is wired for and what voltage service to use.



### WARNING



**IMPROPER GROUNDING COULD RESULT IN ELECTRICAL SHOCK!** Unit is equipped with a three prong (grounded) plug for your protection against electrical shock hazard and should be plugged directly into a properly grounded three prong receptacle. Do not cut or remove the grounding prong from this plug.

## EQUIPMENT PREPARATION

Clean the unit before using. Wipe body and inside of unit with a hot, wet cloth to remove any shipping dust or protective oil.



### WARNING



This unit is not intended to hold potentially hazardous food such as un-cooked or un-preserved meats and sausages.

## ADJUSTING FOR VARIABLE CHINA SIZES

### INSTRUCTIONS:

#### **6½" to 9¾" china:**

Align outermost hole in tube head with the storage hole as shown in Figure 1 below. Insert rods into desired setting and securely screw down rod stops.

#### **10¾" china:**

Rotate tube head to position shown in figure 2. Insert rods through unit so they pass inside the black head weldment below and outside the offset ring weldment to which the springs are attached. Securely screw down rod stops. This will allow for greater stability and improved rod alignment at the 10¾" china size.

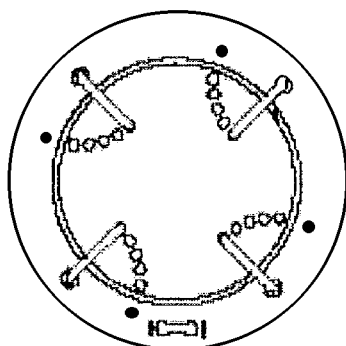

Figure #1

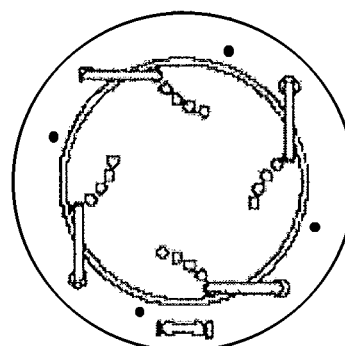
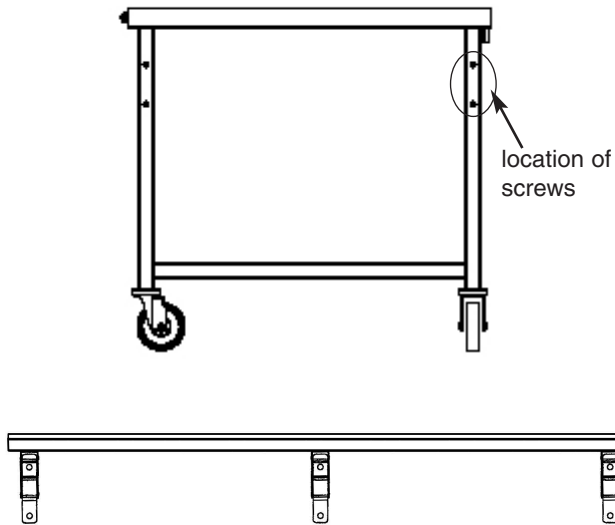

Figure #2

# Director's Choice® Dish/Cup Dispenser Unit

## ASSEMBLY INSTRUCTIONS

### Tray Slides



1. Remove screws from the front of the unit.
2. Hold tray slide up to unit and align the holes with the predrilled screw holes in the unit.
3. Tighten screws and make sure tray slide is securely mounted on unit.

### Work Shelves

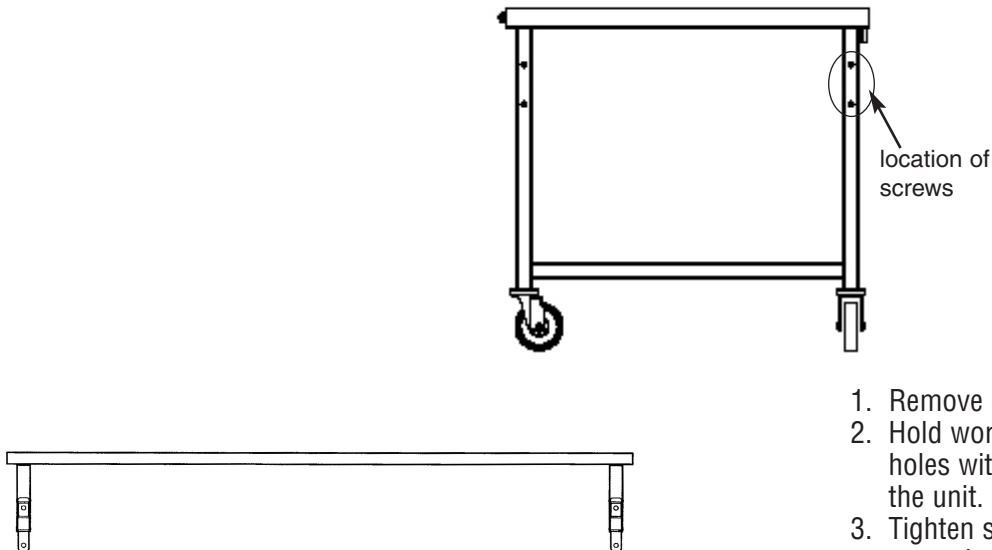

1. Remove screws from the front of the unit.
2. Hold work shelf up to unit and align the holes with the predrilled screw holes in the unit.
3. Tighten screws and make sure tray slide is securely mounted on unit.