



Profit from the Eagle Advantage®

Specification Sheet

Short Form Specifications

Eagle worktables, Budget series, model _____.
 Top constructed of heavy gauge type 430 stainless steel with 1½" roll on front, 1½" rear upturn, and sides turned down 90°. Open front with 1½" O.D. stainless steel tubular crossbracing on sides and rear. Top reinforced with welded hat channels and sound deadened. Constructed with uni-lok® patented gusset system with the gussets recessed into the hat channels to reduce lateral movement. Legs are 1½" O.D. stainless steel tubing, with stainless steel gussets and 1" stainless steel adjustable bullet feet.



worktable with upturn and tubular base
 —shown with optional drawer

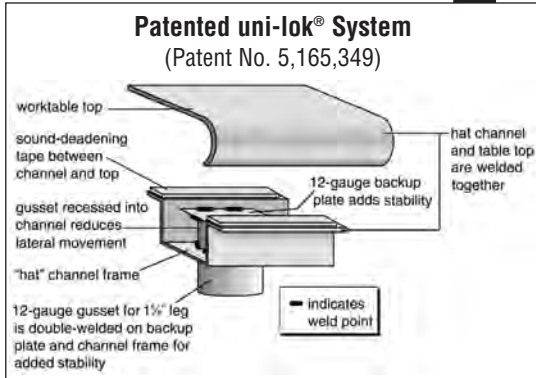

Item No.: _____
 Project No.: _____
 S.I.S. No.: _____

Worktables with Rear Upturn and Stainless Steel Tubular Base —Budget Series

MODELS:

- | | | | |
|------------------------------------|-------------------------------------|-------------------------------------|-------------------------------------|
| <input type="checkbox"/> UT2424STB | <input type="checkbox"/> UT24108STB | <input type="checkbox"/> UT3072STB | <input type="checkbox"/> UT3660STB |
| <input type="checkbox"/> UT2430STB | <input type="checkbox"/> UT24120STB | <input type="checkbox"/> UT3084STB | <input type="checkbox"/> UT3672STB |
| <input type="checkbox"/> UT2436STB | <input type="checkbox"/> UT24132STB | <input type="checkbox"/> UT3096STB | <input type="checkbox"/> UT3684STB |
| <input type="checkbox"/> UT2448STB | <input type="checkbox"/> UT24144STB | <input type="checkbox"/> UT30108STB | <input type="checkbox"/> UT3696STB |
| <input type="checkbox"/> UT2460STB | <input type="checkbox"/> UT3030STB | <input type="checkbox"/> UT30120STB | <input type="checkbox"/> UT36108STB |
| <input type="checkbox"/> UT2472STB | <input type="checkbox"/> UT3036STB | <input type="checkbox"/> UT30132STB | <input type="checkbox"/> UT36120STB |
| <input type="checkbox"/> UT2484STB | <input type="checkbox"/> UT3048STB | <input type="checkbox"/> UT30144STB | <input type="checkbox"/> UT36132STB |
| <input type="checkbox"/> UT2496STB | <input type="checkbox"/> UT3060STB | <input type="checkbox"/> UT3648STB | <input type="checkbox"/> UT36144STB |

Tabletop

- Top reinforced with welded-on hat channel.
- Sound-deadened between top and channels.
- 1½" (38mm) 90° rear upturn with radius at intersection.
- 1½" (41mm)-diameter 180° rolled edge on front. Ends are turned down 90° providing for flush installations when required.
- Heavy gauge type 430 polished stainless steel.

Crossbracing—1¼" (32mm)-diameter

- Heavy gauge stainless steel.
- Aluminum castings join crossbraces, legs and rear brace.

Legs—1½" (41mm)-diameter

- Units 96" to 120" (2438 to 3048mm) long come with six legs; Units 132" and 144" (3353 and 3658mm) come with eight legs.
- Patented uni-lok® gusset system (patent # 5,165,349): gussets are recessed into hat channel, reducing lateral movement.
- Heavy gauge stainless steel.
- Galvanized gussets.
- 1" (25mm) adjustable stainless steel feet.

Options / Accessories

- | | |
|--|--|
| <input type="checkbox"/> Drawer | <input type="checkbox"/> Duplex receptacles |
| <input type="checkbox"/> Lock | <input type="checkbox"/> Pot rack |
| <input type="checkbox"/> Casters | <input type="checkbox"/> Sink |
| <input type="checkbox"/> Stainless steel bullet feet | <input type="checkbox"/> Additional undershelf |
| <input type="checkbox"/> Overshelves | <input type="checkbox"/> Stabilizer Bar (for 30"- and 36"-wide tables) |



EAGLE GROUP
 100 Industrial Boulevard, Clayton, DE 19938-8903 USA
 Phone: 302-653-3000 • Fax: 302-653-2065
 www.eaglegrp.com

Foodservice Division: Phone 800-441-8440
MHC/Retail Display Divisions: Phone 800-637-5100

For custom configuration or fabrication needs, contact our **SpecFAB® Division**.
 Phone: 302-653-3000 • Fax: 302-653-2065 • e-mail: quotes@eaglegrp.com

EG10.49A Rev. 11/15

Spec sheets available for viewing, printing or downloading from our online literature library at www.eaglegrp.com



Item No.: _____
 Project No.: _____
 S.I.S. No.: _____

Worktables with Rear Uprturn and Stainless Steel Tubular Base —Budget Series

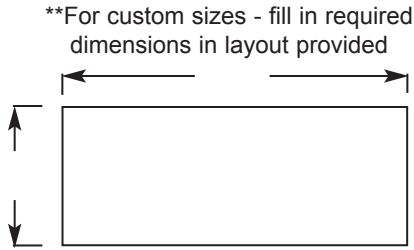

TOP VIEW

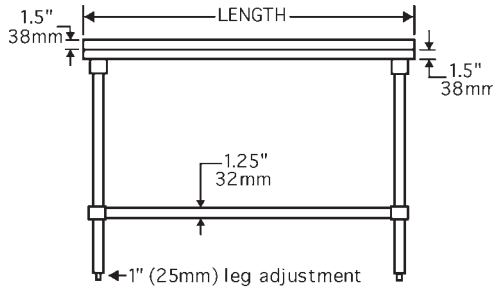

FRONT VIEW

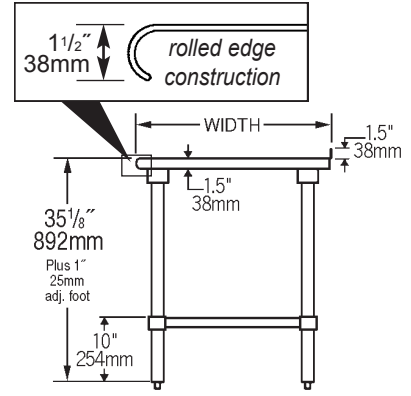

SIDE VIEW

model #	# of legs	width		length		weight	
		in.	mm	in.	mm	lbs.	kg
UT2424STB	4	24"	610	24"	610	40	18.1
UT2430STB	4	24"	610	30"	762	45	20.4
UT2436STB	4	24"	610	36"	914	50	22.7
UT2448STB	4	24"	610	48"	1219	60	27.2
UT2460STB	4	24"	610	60"	1524	70	31.8
UT2472STB	4	24"	610	72"	1829	80	36.3
UT2484STB	4	24"	610	84"	2134	90	40.8
UT2496STB	6	24"	610	96"	2438	100	45.4
UT24108STB	6	24"	610	108"	2743	110	49.9
UT24120STB	6	24"	610	120"	3048	120	54.4
UT24132STB	8	24"	610	132"	3353	130	59.0
UT24144STB	8	24"	610	144"	3658	140	63.5
UT3030STB	4	30"	762	30"	762	50	22.7
UT3036STB	4	30"	762	36"	914	53	24.0
UT3048STB	4	30"	762	48"	1219	57	25.9
UT3060STB	4	30"	762	60"	1524	67	30.4
UT3072STB	4	30"	762	72"	1829	77	34.9
UT3084STB	4	30"	762	84"	2134	87	39.5
UT3096STB	6	30"	762	96"	2438	97	44.0
UT30108STB	6	30"	762	108"	2743	107	48.5
UT30120STB	6	30"	762	120"	3048	117	53.1
UT30132STB	8	30"	762	132"	3353	127	57.6
UT30144STB	8	30"	762	144"	3658	137	62.1
UT3648STB	4	36"	914	48"	1219	61	27.7
UT3660STB	4	36"	914	60"	1524	72	32.7
UT3672STB	4	36"	914	72"	1829	85	38.6
UT3684STB	4	36"	914	84"	2134	97	44.0
UT3696STB	6	36"	914	96"	2438	109	49.4
UT36108STB	6	36"	914	108"	2743	121	54.9
UT36120STB	6	36"	914	120"	3048	133	60.3
UT36132STB	8	36"	914	132"	3353	145	65.8
UT36144STB	8	36"	914	144"	3658	157	71.2

EAGLE GROUP
 100 Industrial Boulevard, Clayton, DE 19938-8903 USA
 Phone: 302-653-3000 • Fax: 302-653-2065
 www.eaglegrp.com

Foodservice Division: Phone 800-441-8440
 MHC/Retail Display Divisions: Phone 800-637-5100

Printed in U.S.A.
 ©2015 by Eagle Group
 Rev. 11/15

Spec sheets available for viewing, printing or downloading from our online literature library at www.eaglegrp.com

Although every attempt has been made to ensure the accuracy of the information provided, we cannot be held responsible for typographical or printing errors. Information and specifications are subject to change without notice. Please confirm at time of order.