



Profit from the Eagle Advantage®

Specification Sheet

Short Form Specifications

Eagle Spec-Bar® Mini Bottle Rack, model _____. Heavy gauge type 304 stainless steel. Underbar or countertop model available.



countertop model

Options / Accessories

Locking covers

Item No.:	_____
Project No.:	_____
S.I.S. No.:	_____

Spec-Bar® Mini Bottle Racks

MODELS:

BRM-24CT

BRM-24

Design and Constructions Features

- Body, legs and crossbracing constructed of type 304 stainless steel for strength and corrosion resistance.
- Trays are constructed of 20 gauge stainless steel.
- Sides are 14 gauge stainless steel.
- Leg channels, legs and crossbracing are 16 gauge stainless steel.
- Legs on #BRM-24 are 15/8" (41mm)-diameter, with stainless steel adjustable bullet feet.
- Countertop model #BRM-24-CT holds 252 bottles.
- Underbar model #BRM-24 holds 510 bottles.

EAGLE GROUP

100 Industrial Boulevard, Clayton, DE 19938-8903 USA
 Phone: 302-653-3000 • 800-441-8440 • Fax: 302-653-2065
www.eaglegrp.com
www.eaglemhc.com

For custom configuration or fabrication needs, contact our SpecFAB® Division.
 Phone: 302-653-3000 • Fax: 302-653-2065 • e-mail: quotes@eaglegrp.com

Certifications / Approvals



AutoQuotes





Item No.: _____
 Project No.: _____
 S.I.S. No.: _____

Spec-Bar® Mini Bottle Racks

Countertop Model—12" (305mm) wide

BOTTLE CAPACITY: APPROXIMATELY 252

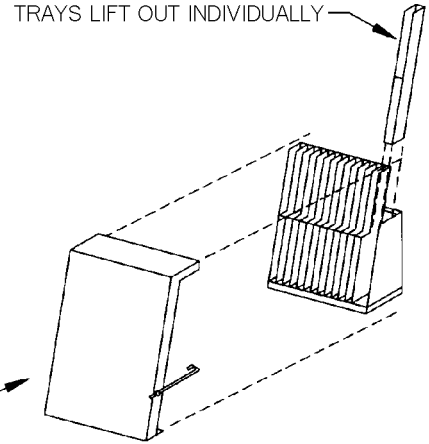
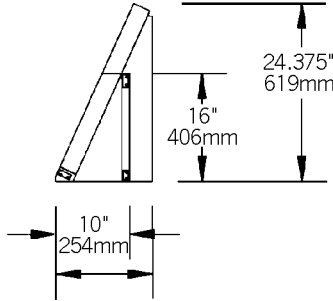
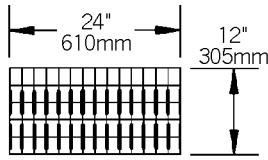

OPTIONAL LOCKING COVER
 MODEL #BRM-CTLC-24

model #	width in. mm	length in. mm	weight lbs. kg
BRM-24CT	12" 305	24" 610	35 15.9

Underbar Model—24" (610mm) wide

BOTTLE CAPACITY: APPROXIMATELY 510

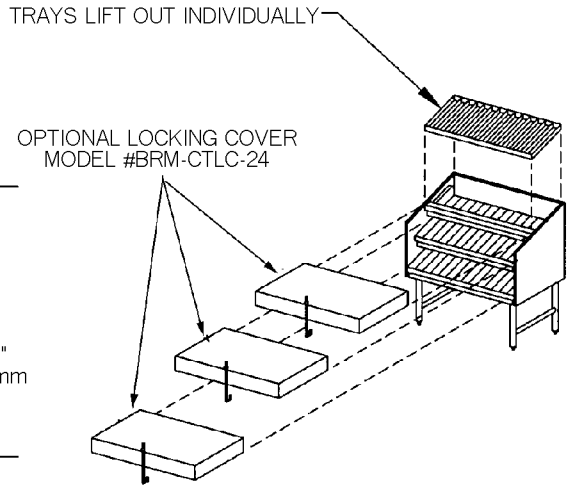
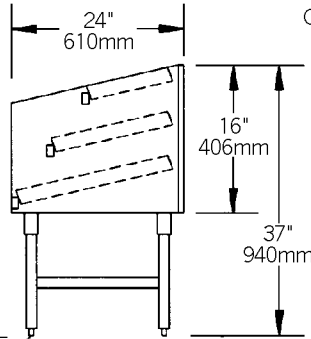
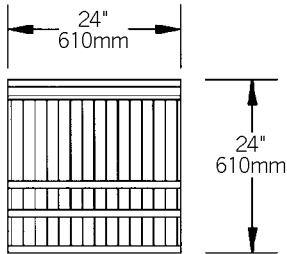

OPTIONAL LOCKING COVER
 MODEL #BRM-CTLC-24

1" (25mm) ADJUSTABLE
 FROM 37" (940mm)
 TO 38" (965mm)

model #	width in. mm	length in. mm	weight lbs. kg
BRM-24	24" 610	24" 610	95 43.1

EAGLE GROUP
 100 Industrial Boulevard, Clayton, DE 19938-8903 USA
 Phone: 302-653-3000 or 800-441-8440 • Fax: 302-653-2065
 www.eaglegrp.com • www.eaglehmc.com

Printed in U.S.A.
 ©2024 by Eagle Group

Rev. 10/24

Spec sheets available for viewing, printing or downloading from our online literature library at our websites

Although every attempt has been made to ensure the accuracy of the information provided, we cannot be held responsible for typographical or printing errors. Information and specifications are subject to change without notice. Please confirm at time of order.