

Panco® Display Rack

ASSEMBLY INSTRUCTIONS

CAUTION

INSPECT CONTENTS IMMEDIATELY AND FILE CLAIM WITH DELIVERING CARRIER FOR ANY DAMAGE. **SAVE YOUR BOX AND ALL PACKING MATERIALS.** YOU ARE RESPONSIBLE FOR DAMAGE TO YOUR UNIT IF RETURNED IMPROPERLY PACKED.

Parts List

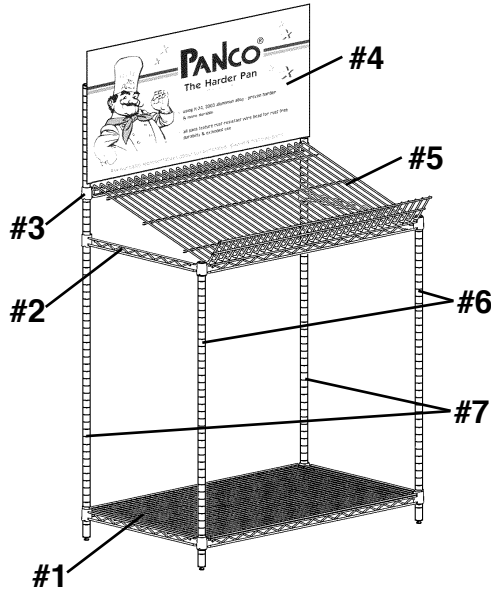

#	qty	description
#1	1	18" x 30" wire shelf
#2	1	three sided truss frame
#3	1	single truss frame 30"
#4	1	Panco® display sign
#5	1	top display shelf
#6	2	40" post
#7	2	63" post with velcro
#8	3	bags of 4 split sleeves

(not shown)

qty	description
1	peel-off label for display pan

Step 1 - Attach split sleeves (for bottom shelf) to posts.

Snap split sleeve onto each post at the bottom groove covering #3 (the wider part of the taper goes toward the bottom).

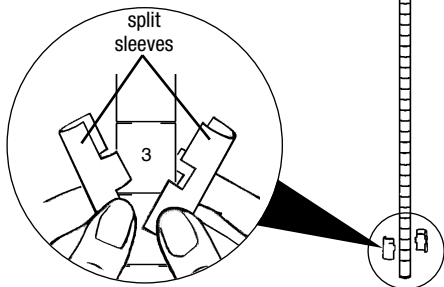

Step 2 - Assemble bottom shelf to posts.

Note: Make sure the velcro on rear posts are facing towards the front.

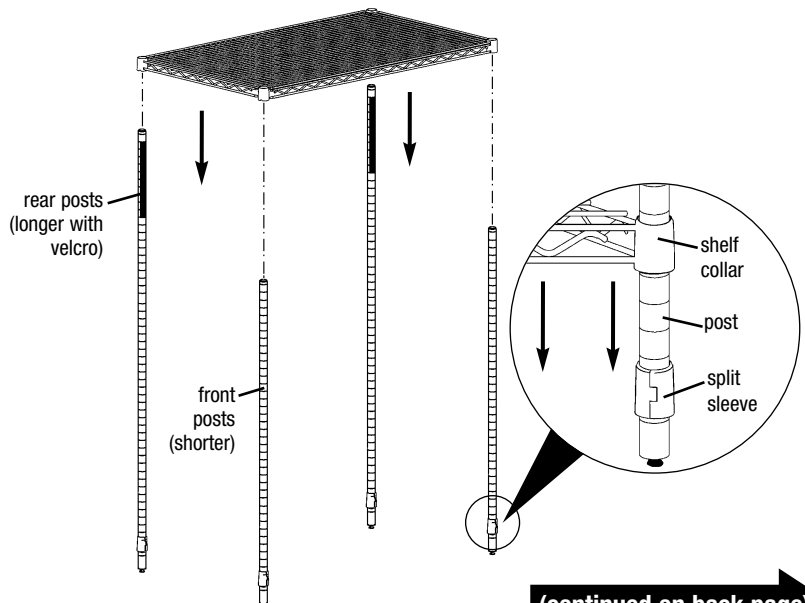

(continued on back page)

EG10039 Revised 08/23

Panco® Display Rack

ASSEMBLY INSTRUCTIONS

Step 3 - Attach split sleeves (for 3-sided frame) to posts.

Snap split sleeve onto each post at the groove covering #39 (top of front posts).

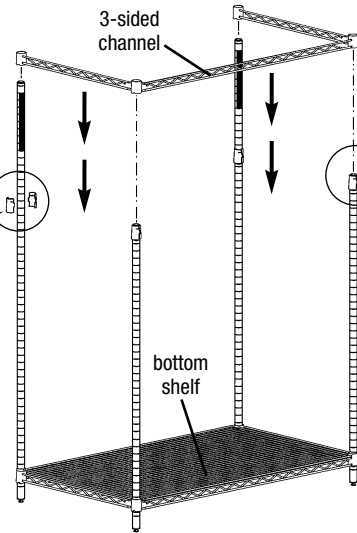
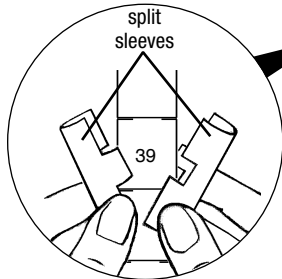

Step 4 - Assemble 3-sided frame to posts.

Note: Long side goes to the front of the unit (short posts).

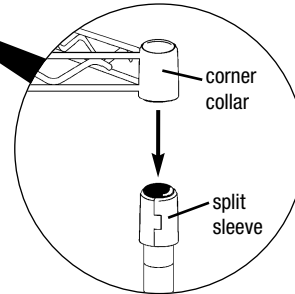

Step 5 - Attach split sleeves (for rear truss) to posts.

Snap split sleeve onto each rear post at the groove covering #46.

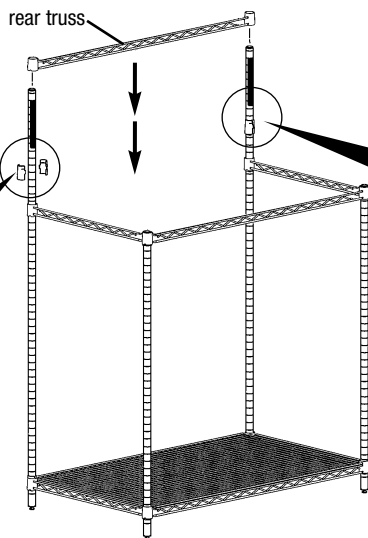
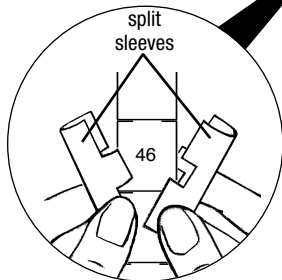

Step 6 - Assemble rear truss to posts.

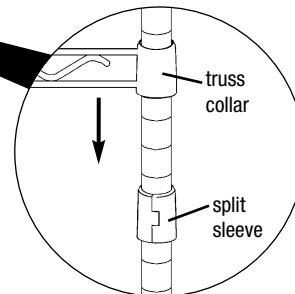

Step 7 - Install display shelf.

Hook display shelf over rear truss with short flange down, allowing front of shelf to rest on 3-sided frame.

(Note: If shelf does not fit correctly, lower rear truss.)

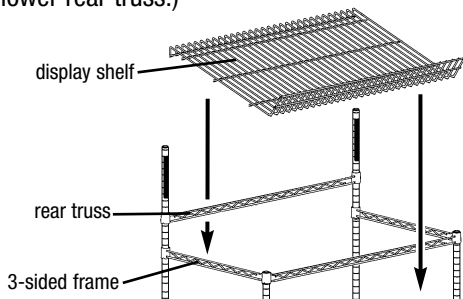

Step 8 - Attach sign to rear posts (using velcro supplied).

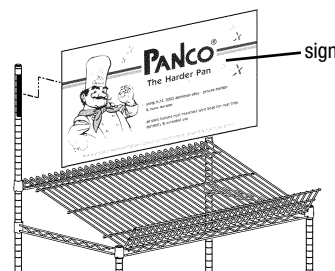

Load pans onto bottom shelf, load one pan onto display shelf, and attach peel-off label to pan on display shelf.

(End)

