

Cantilevered Shelving

Freestanding / Back-to-Back Unit

INSTALLATION INSTRUCTIONS

CAUTION

INSPECT CONTENTS IMMEDIATELY AND FILE CLAIM WITH DELIVERING CARRIER FOR ANY DAMAGE.
SAVE YOUR BOX AND ALL PACKING MATERIALS.
 YOU ARE RESPONSIBLE FOR DAMAGE TO YOUR UNIT IF RETURNED IMPROPERLY PACKED.

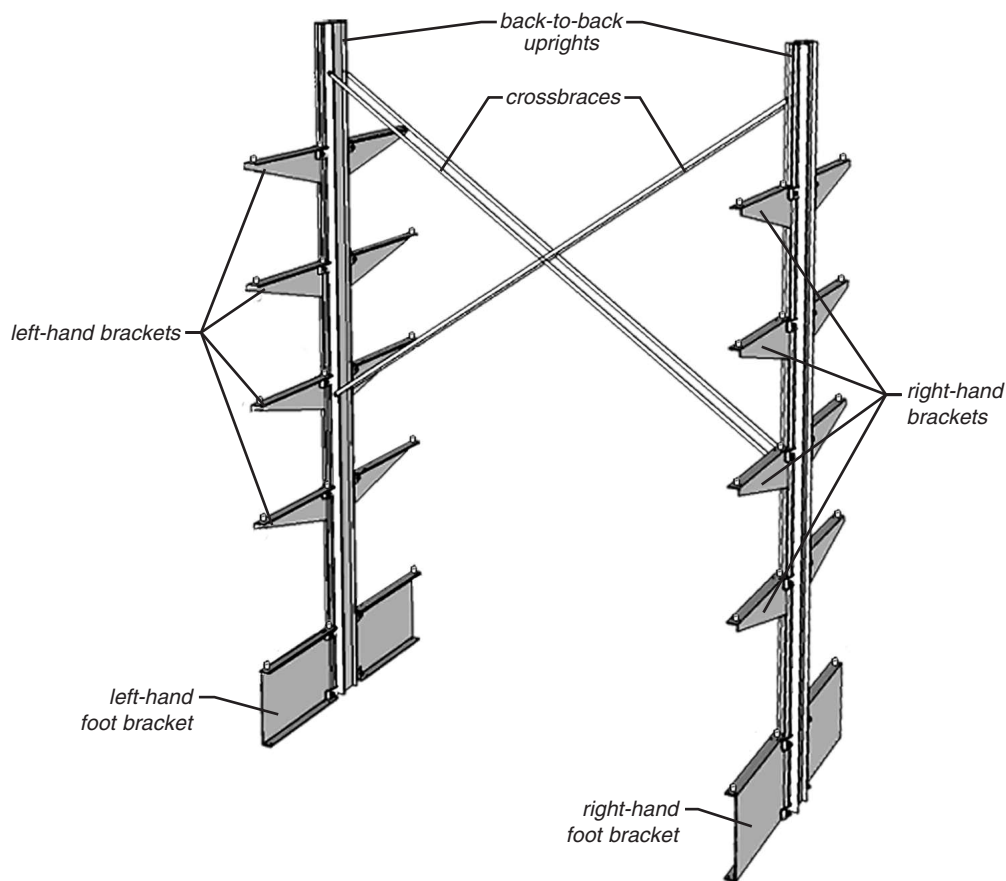

Shelves not shown.

Before assembly:

Lay out all uprights on the floor (face up), with corresponding foot brackets, spaced the proper distance apart (determined by shelf length).

See illustration at right.

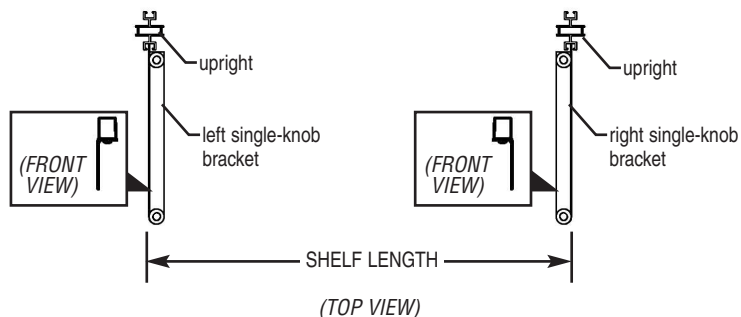

(continued on back page)

EG9972 Revised 11/11

Cantilevered Shelving Freestanding / Back-to-Back Unit

INSTALLATION INSTRUCTIONS

A. Bracket-to-Upright Assembly

ASSEMBLE FOOT BRACKETS FIRST.

NOTE: Foot brackets serve as a base for the bottom shelf.

- Starting with the first two uprights, insert a single flange foot bracket in the groove of the upright, making sure it is flush with the end of the upright. Flanges should "point" in the direction of the shelving run—see far right.

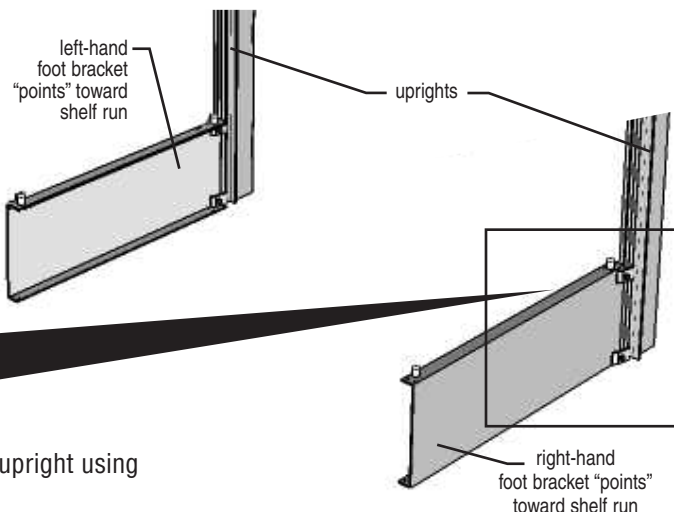
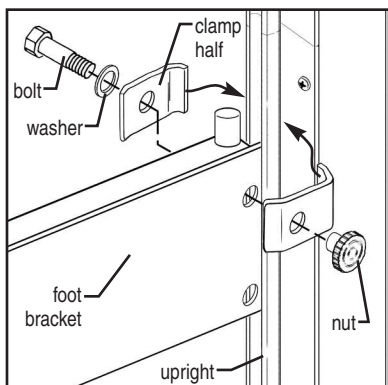

- Place a clamp half on either side of the foot bracket and fasten to the upright using the 3/8" x 1-1/2" hex head bolt and accompanying nut, then tighten.
- Continue with the second clamp/bolt assembly for this foot bracket, as illustrated.

PROCEED UP THE UPRIGHT, MOUNTING REGULAR SINGLE FLANGE BRACKETS, WHICH ARE FOR THE UPPER SHELVES.

NOTE: Continuous shelving runs, which consist of more than two uprights, use DOUBLE BRACKETS and DOUBLE FOOT BRACKETS.

- These "doubles" attach to the inner upright(s) and are used for joining two shelves together on a single common upright.
- End uprights will always use single-flange brackets and foot brackets.
- With brackets and foot brackets attached to the first two uprights, slide the upper brackets to their correct heights and tighten.

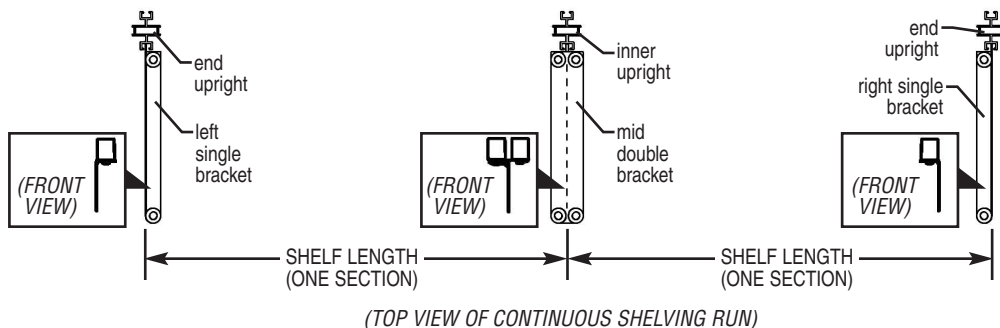

B. Shelf-to-Bracket Assembly

Lower corner collars of shelf onto bracket knobs—see illustration at right.

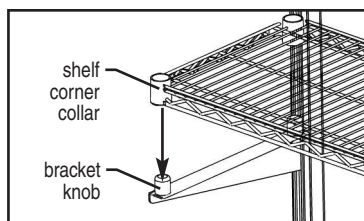

C. X-Brace Installation

- Measure down 6" from the top of the upright (see illustration at right) and 3/4" from the center web of the upright.
- Mark and drill a 1/4" hole.
- Place the X-brace on the front side of the upright, at this hole, and attach with the 1/4" machine screw provided.
- Swing the bottom of the X-brace up until it meets the adjoining upright and mark it also 3/4" from the center web of the upright.
- Drill a 1/4" hole at this point and fasten with a 1/4" machine screw.

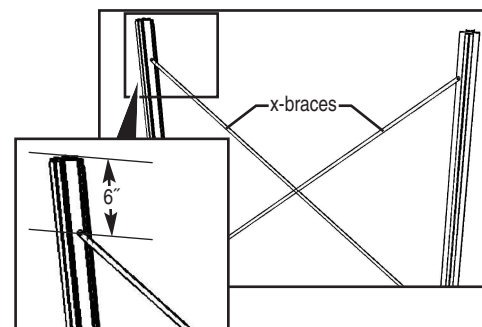

On continuous shelving runs: Remember, there are two (2) X-braces per section. After assembling the first section, lift to the upright position and continue assembly with the remaining sections now in the vertical position.

(End)



• 100 Industrial Boulevard, Clayton, Delaware 19938-8903 U.S.A. • www.eaglegrp.com
 • Phone: 302/653-3000 • (Foodservice/SpecFAB) 800/441-8440 • (MHC/Retail) 800/637-5100
 • Fax: 302/653-2065

Eagle Foodservice Equipment, Eagle MHC, SpecFAB®, and Retail Display are divisions of Eagle Group. ©2011 by the Eagle Group