

Sinks

ASSEMBLY INSTRUCTIONS

CAUTION

INSPECT CONTENTS IMMEDIATELY AND FILE CLAIM WITH DELIVERING CARRIER FOR ANY DAMAGE. **SAVE YOUR CRATE AND ALL PACKING MATERIALS.** YOU ARE RESPONSIBLE FOR DAMAGE TO YOUR UNIT IF RETURNED IMPROPERLY PACKED.

BEFORE ASSEMBLY, PLEASE READ:

Local codes regarding installation vary by location. Installation must comply with all required codes. Contact the authorities in your area having jurisdiction over requirements for installation of this equipment.

Remove contents from crate. Verify that all contents listed are included. Consult the factory, the factory representative or Eagle's authorized service center in your area if parts are missing.

CONTENTS:

BPFC Series Sinks

- (1) Sink Unit
- (4) Legs
- (2) Front Castings
- (2) Corner Castings
- (1) End-to-End Crossbrace
- (2) Front-to-Back Crossbraces
- (14) Set Screws
- (1) Assembly Instructions
- Drain(s)*, 1-1/2" NPS - with coupling nut, gasket, and sealing washer

BPFE Series Sinks

- (1) Sink Unit
- (4) Legs
- (14) Set Screws
- (1) Assembly Instructions
- Drain(s)*, 1-1/2" NPS - with coupling nut, gasket, and sealing washer

Tools required:
• 5/32" allen wrench

* Quantity of drains depends on quantity of sink bowls included with sink ordered.

Step 1 - Assemble and attach crossbrace assembly and legs.

- Place sink upside down (see *figure 1*).
- Insert top of legs into gussets.

Please note...

If you have a BPFC Series sink, follow this step.
If you have a BPFE Series sink, skip this step.

- Assemble all crossbraces, front castings and corner castings as shown (*figure 1*). Using allen wrench, secure crossbraces into castings —1 set screw* per front casting, 2 set screws* per corner casting.
- Using allen wrench, secure legs into gussets (see *figure 1a*)—1 set screw* per gusset. Secure crossbrace assembly onto legs (6" min. from bottom) —1 set screw* per casting.
- Place sink in its upright position (might require assistance).

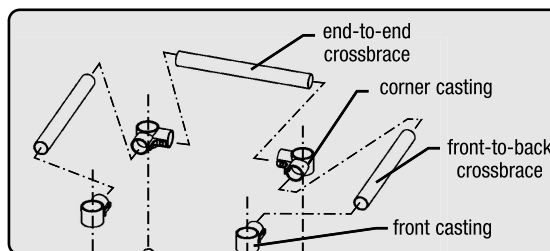

Please note...

Only BPFC Series sinks utilize crossbracing.

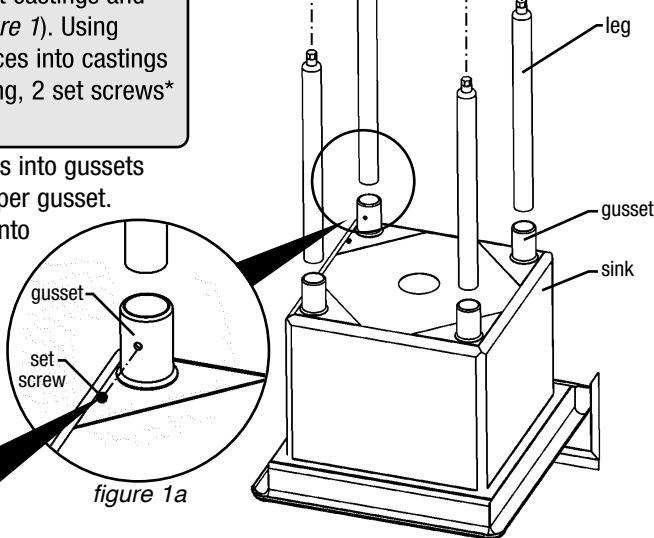

Step 2 - Install drain(s) and faucet(s), provided separately.

Follow instructions provided with hardware for installation.

*** To meet NSF standards:**

Set screws must be filled with NSF-approved sealant.



(continued on back page)

Sinks

ASSEMBLY INSTRUCTIONS

Step 3 - Level sink.

- Place sink in the intended installation location.
- Level sink by turning adjustable bullet foot (see figure 2) on each leg.

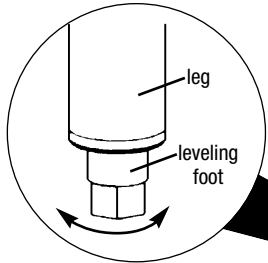
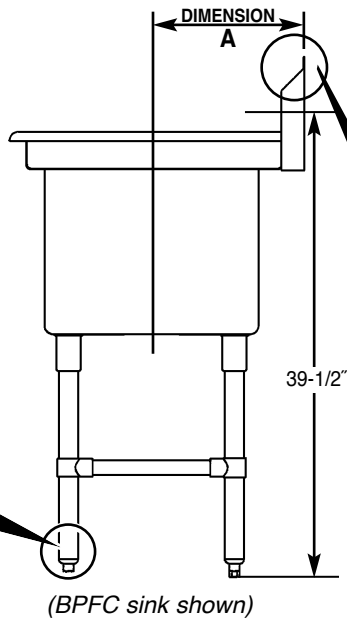

figure 2



(BPF sink shown)

Step 4 - Plumb drain(s) and water supply lines, referring to chart below and illustration at left.

bowl size (inches)	DIMENSION A (inches)
15" x 15"	10½"
18" x 18"	11"
24" x 24"	15"

Step 5 - Secure and seal unit to wall as required.

For NSF approval:

- Apply silicone sealant along the topmost flange of backsplash, or...
- Cover topmost flange with finished wall.

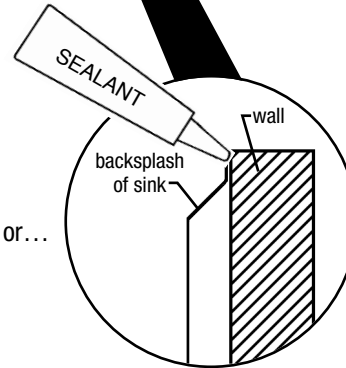

Step 6 - Flush system and check for leaks.



CLEANING INSTRUCTIONS

Properly cared for, sink will last indefinitely. Improper use of commercial chemicals, sterilizers, and detergents may cause corrosion, discoloring, and pitting. For best results, follow these recommendations:

- You must clean sink thoroughly and flush with water after using detergent and sterilizers.
- NEVER LEAVE SOLUTIONS IN SINK OVERNIGHT.
- Use solutions ONLY IN STRENGTH RECOMMENDED BY MANUFACTURER, or they may cause severe damage. High content of chlorine, chlorine derivatives, or bleach are not recommended for stainless steel bowls, for they cause pitting or corrosion.
- Avoid spillage or splashing of full-strength chemicals directly onto stainless steel surface. Always put water in sink before adding sanitizing agents or soaps.
- Between cleanings, wipe the stainless steel sink with a damp cloth. Deposits of dirt or grease in sinks provide local points of attack.
- CAUTION: NEVER USE ORDINARY STEEL WOOL. Use only stainless steel wool or scouring pads.
- DO NOT USE steel scrapers to clean stainless steel.

NOTE: A discoloration may show at the seams, which is SURFACE RUST. It may be caused by the iron in your water or strong detergents. CLEAN AT ONCE with any good strong cleanser.