



Profit from the Eagle Advantage®

Specification Sheet

Short Form Specifications

Eagle Director's Choice Tray / Silverware / Napkin Dispenser Unit, model #DCS3034-TSND. Top to be 16/304 stainless steel turned down on all sides. 1½" square type 304 stainless steel all-welded tubular base. Quick release spring loaded docking device keeps adjoining units together. Self-leveling tray dispenser accommodates up to 150 trays. Napkin dispenser holds up to 750 napkins. Four 3¾"-diameter polyethylene silverware cylinders. Fully mobile with 5" poly tread casters, two with brake. Standard laminate front panel is holly berry red (Wilsonart® #D307-60).



#DCS3034-TSND unit

Options / Accessories

- Stainless steel end panels Work shelf**
- Stainless steel front panel Specify laminate _____
- Stainless steel tray slide*

* Available in solid ribbed, square tubular or round tubular. For front, rear, or ends.

** Available in hardwood, stainless steel, poly, or Richlite®. For front, rear, or ends.

EAGLE GROUP

100 Industrial Boulevard, Clayton, DE 19938-8903 USA
Phone: 302-653-3000 • 800-441-8440 • Fax: 302-653-2065
www.eaglegrp.com
www.eaglemhc.com

For custom configuration or fabrication needs, contact our SpecFAB® Division.
Phone: 302-653-3000 • Fax: 302-653-2065 • e-mail: quotes@eaglegrp.com

Item No.:	_____
Project No.:	_____
S.I.S. No.:	_____

Director's Choice® Tray-Silverware-Napkin Dispenser Unit

MODELS:

- DCS3034-TSND

Design and Construction Features

- Top is constructed of 16 gauge type 304 stainless steel, die-formed, welded, and polished.
- Four 3¾" (95mm)-diameter polyethylene silverware cylinders.
- Sized for 14" x 18" or 15" x 20" (356 x 457 or 381 x 508mm) trays, and 3¾" x 6½" (95 x 165mm) napkins.
- Self-leveling tray dispenser with adjustable height holds approximately 150 trays.
- Napkin dispenser holds up to 750 Minifold napkins.
- Welded 1½" (38mm) type 304 stainless steel square tubular base construction.
- Three working heights available—see Catalog Sheet EG33.07A:
 - 34" (864mm) standard working height complies with ADA guidelines for accessibility standards.
 - 30" (762mm) for middle schools.
 - 28" (711mm) low profile for elementary schools and nursing/healthcare facilities.
- Tray slide heights available—see Catalog Sheet EG33.07A:
 - 31" (787mm) standard height for high schools.
 - 27" (686mm) standard height for middle schools.
 - 25" (635mm) height for elementary schools and nursing/healthcare facilities.
- Fully mobile – standard 5" (127mm) poly tread casters, two with brake (brake casters on server side).
- Quick-release spring-loaded docking device keeps adjoining units together without the use of tools.
- Standard holly berry red (Wilsonart® D307-60) laminate mounted on 18 gauge galvanized subpanel.
- All units accommodate optional accessories, including tray slides and work shelves. See Catalog Sheet EG33.07A.



EG33.16 Rev. 08/24

Spec sheets available for viewing, printing or downloading from our online literature library at our websites

Eagle Foodservice Equipment, Eagle MHC, and SpecFAB® are divisions of Eagle Group. ©2024 by the Eagle Group



Item No.: _____
 Project No.: _____
 S.I.S. No.: _____

Director's Choice® Tray-Silverware-Napkin Dispenser Unit

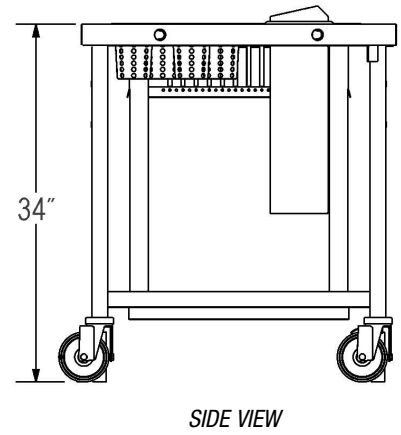
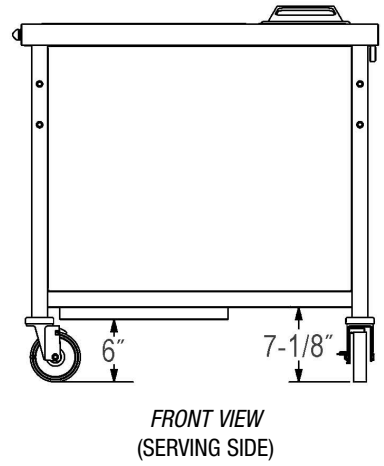
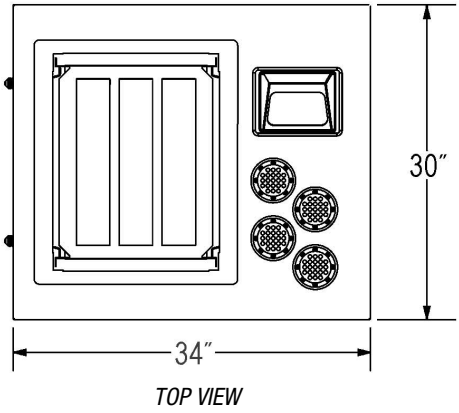

model #	length		weight		14" x 18" & 15" x 20" tray cap.
	in.	mm	lbs.	kg	
DCS3034-TSND	34"	864	270	122.5	150

Optional stainless steel front panel in lieu of laminate front panel available. To order, add suffix "-S" to model number. Example: DSC3034-TSND-S
 Optional stainless steel end panels available. To order, add suffix "-SEP" to model number. Example: DSC3034-TSND-S-SEP

EAGLE GROUP
 100 Industrial Boulevard, Clayton, DE 19938-8903 USA
 Phone: 302-653-3000 or 800-441-8440 • Fax: 302-653-2065
 www.eaglegrp.com • www.eaglehmc.com

Printed in U.S.A.
 ©2024 by Eagle Group
 Rev. 08/24

Spec sheets available for viewing, printing or downloading from our online literature library at our websites

Although every attempt has been made to ensure the accuracy of the information provided, we cannot be held responsible for typographical or printing errors. Information and specifications are subject to change without notice. Please confirm at time of order.