



Profit from the Eagle Advantage®

Specification Sheet

Short Form Specifications

Eagle Hand Sink, model HSA-10-FDP. Constructed of type 304 stainless steel, all-welded with deep-drawn positive drain sink bowl, inverted "V" edge to prevent spillage, drain, paper towel dispenser, soap dispenser and splash mounted gooseneck faucet.

Eagle Hand Sink, model HSA-10-FDPS. Features are the same as #HSA-10-FDP, plus stainless steel sink skirt.

Eagle Hand Sink, model HSA-10-FLDP. Features are the same as #HSA-10-FDP, plus polymer lever drain.

Eagle Hand Sink, model HSA-10-FODP. Features are the same as #HSA-10-FDP, plus polymer lever drain with overflow.

Eagle Hand Sink, model HSA-10-FWLDP-LRS. Features splash mount gooseneck faucet with wrist handles, towel dispenser, soap dispenser, polymer lever drain, and end splashes.



#HSA-10-FDP

Options / Accessories

- P-trap
- Tail piece
- End splashes
- Front skirt**
- Side mount wall bracket
- MICROGARD® antimicrobial agent***

** Front skirt available only for models HSA-10-FDP and HSA-10-FDPS.

*** For hand sinks #HSA-10-FDP and #HSA-10-FDPS only.

EAGLE GROUP

100 Industrial Boulevard, Clayton, DE 19938-8903 USA
Phone: 302-653-3000 • 800-441-8440 • Fax: 302-653-2065
www.eaglegrp.com
www.eaglehmc.com

For custom configuration or fabrication needs, contact our SpecFAB® Division.
Phone: 302-653-3000 • Fax: 302-653-2065 • e-mail: quotes@eaglegrp.com

Item No.:	_____
Project No.:	_____
S.I.S. No.:	_____

Hand Sinks* with Towel and/or Soap Dispenser

MODELS:

- HSA-10-FDP
- HSA-10-FDPS
- HSA-10-FLDP
- HSA-10-FODP
- HSA-10-FWLDP-LRS

Design & Construction Features

- Heavy gauge type 304 stainless steel all-welded construction.
- Inverted "V" edge rim retards spillage.
- Backsplash with a 2" (51mm) return on a 45° angle.
- 1/2" (13mm) NPS water inlet, 1/2" (38mm) NPS drain outlet.
- Unique deep-drawn positive-drain bowl assures complete drainage to meet the most stringent health code requirements.
- All-welded towel dispenser features hinged top assembly, sight window to visually inspect towel level, quick-fill soap dispenser, and is designed to accommodate 4" x 10" (102 x 254mm) C-fold disposable paper towels.
- Comes with mounting bracket to facilitate wall mount installation.

* Non-electric. For hand sinks with electric soap dispenser and faucets, see spec sheet #20.42.

For hand sinks with deck-mounted soap dispensers, see spec sheets #EG20.05 and #EG20.07.

Certifications / Approvals



AutoQuotes



EG20.41 Rev. 06/24

Spec sheets available for viewing, printing or downloading from our online literature library at our websites

Eagle Foodservice Equipment, Eagle MHC, and SpecFAB® are divisions of Eagle Group. ©2024 by the Eagle Group



Profit from the Eagle Advantage®

Item No.: _____
 Project No.: _____
 S.I.S. No.: _____

Hand Sinks with Towel and/or Soap Dispensers

HSA-10-FDP

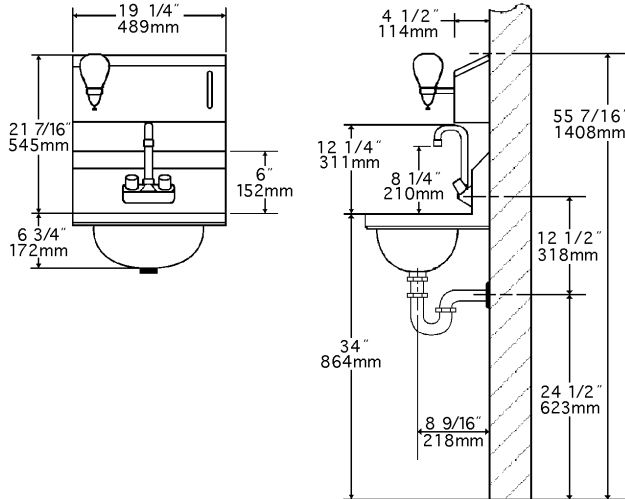

HSA-10-FDPS

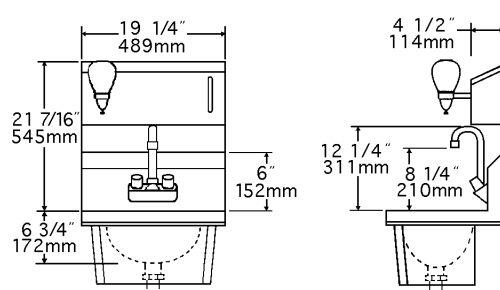

HSA-10-FLDP / HSA-10-FWLDL-LRS

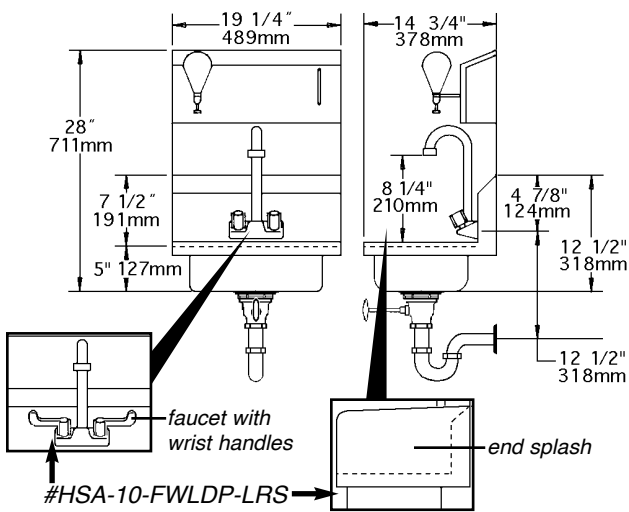

HSA-10-FODP

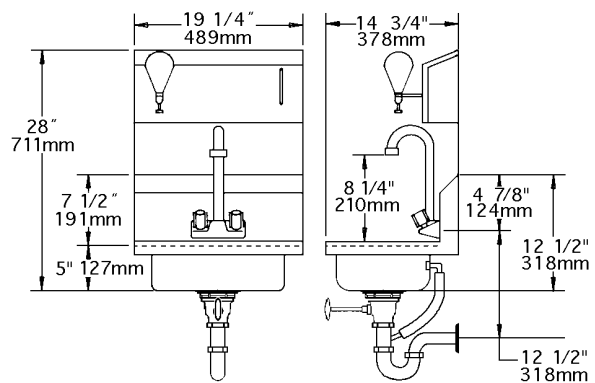

model #	includes towel dispenser, soap dispenser, and...	bowl size		overall size		weight	
		width in.	length x depth mm	width in.	length x height mm	lbs.	kg
HSA-10-FDP	faucet, basket drain	9 3/4"	13 1/2" x 6 3/4"	14 3/4" x 19 1/4" x 28 1/4"	376 x 489 x 718	29	13.2
HSA-10-FDPS	faucet, skirt, basket drain	9 3/4"	13 1/2" x 6 3/4"	14 3/4" x 19 1/4" x 30"	376 x 489 x 762	29	13.2
HSA-10-FLDP	faucet, polymer lever drain	10"	14" x 5"	14 3/4" x 19 1/4" x 28"	376 x 489 x 711	32	14.5
HSA-10-FODP	faucet, polymer lever drain w/overflow	10"	14" x 5"	14 3/4" x 19 1/4" x 28"	376 x 489 x 711	30	13.6
HSA-10-FWLDL-LRS	faucet w/wrist handles, poly lever drain, end splashes	10"	14" x 5"	14 3/4" x 19 1/4" x 28"	376 x 489 x 711	30	13.6

EAGLE GROUP
 100 Industrial Boulevard, Clayton, DE 19938-8903 USA
 Phone: 302-653-3000 or 800-441-8440 • Fax: 302-653-2065
 www.eaglegrp.com • www.eaglemhc.com

Printed in U.S.A.
 ©2024 by Eagle Group

Rev. 06/24

Spec sheets available for viewing, printing or downloading from our online literature library at our websites

Although every attempt has been made to ensure the accuracy of the information provided, we cannot be held responsible for typographical or printing errors. Information and specifications are subject to change without notice. Please confirm at time of order.