

Steril-Eze® Open Wire Surgical Case Carts

ASSEMBLY INSTRUCTIONS

CAUTION

INSPECT CONTENTS IMMEDIATELY AND FILE CLAIM WITH DELIVERING CARRIER FOR ANY DAMAGE.

SAVE YOUR BOX AND ALL PACKING MATERIALS.

YOU ARE RESPONSIBLE FOR DAMAGE TO YOUR UNIT IF RETURNED IMPROPERLY PACKED.

Step 1 - Secure casters to posts.

- Place donut bumpers onto bottom ends of posts.
- Place caster stems into bottom and drive caster using a hammer or mallet (several solid blows are usually required).

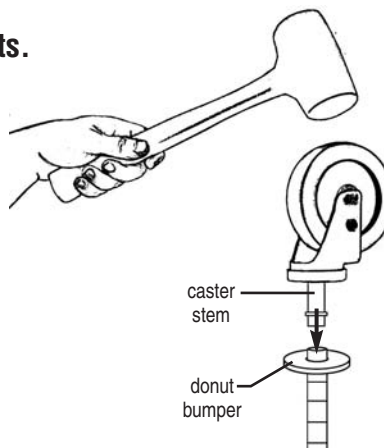

Step 2 - Attach split sleeves (at 3" mark for bottom shelf) to posts.

- The wider part of the taper goes toward the bottom.
- Make sure rib on split sleeve is seated into a groove on the post.

Note: The number covered by the split sleeve indicates approximate height of shelf.

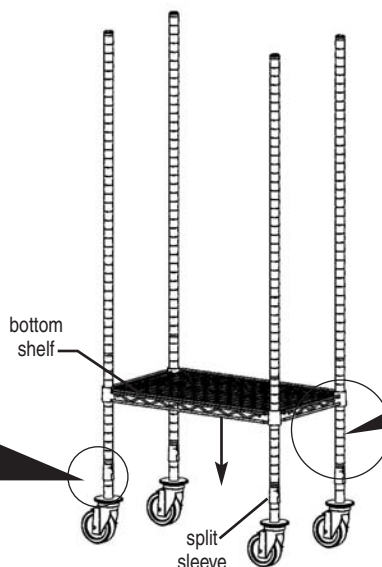
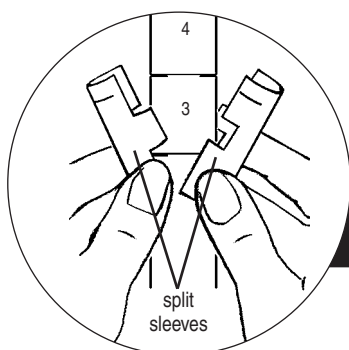

Step 3 - Mount shelf.

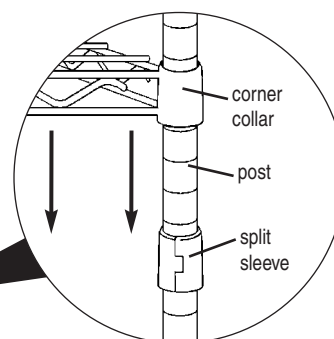

(continued on back page)

EG10016 Revised 02/09

Steril-Eze® Open Wire Surgical Case Carts

ASSEMBLY INSTRUCTIONS

Step 4: Mount additional shelves at desired heights.

Repeat Steps 2 & 3, working from bottom to top.

Step 5: Securely seat all shelves.

Note: Do NOT hammer directly on wire or corner.

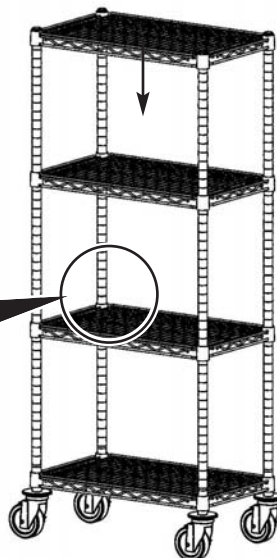
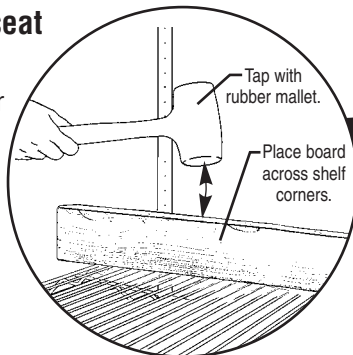

Before installing slides, determine where the clips will be located on the shelf:

- Hold slides together with adjoining tote box and place under wire shelf.
- Note locations of holes on slides. These holes will be the location of the clips.
- Set aside tote box and slides.

Step 6 - Attach clips to desired shelf (two clips per slide).

Hang clips on wires running left-to-right (not front-to-back).

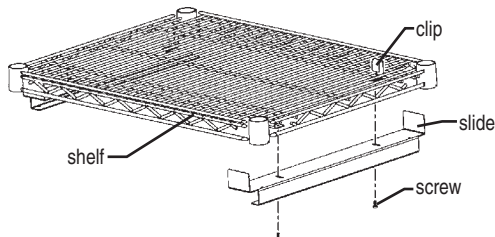

Step 7 - Attach slides to shelf.

Hold slides under shelf and fasten to clip with slotted screws.

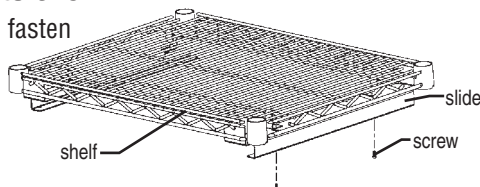

Step 8 - Slide tote box into slides.

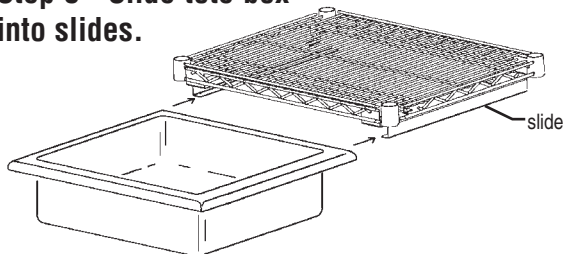

Step 9 - Install enclosure panels on both sides and rear of unit.

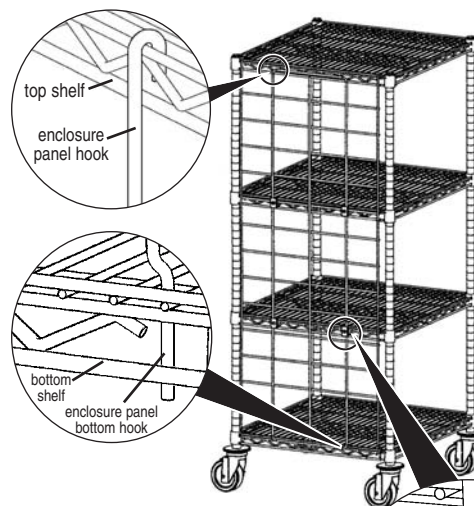

Step 10 - Secure enclosure panel with retaining clamp assemblies

NOTE: Four retaining clamp assemblies required per enclosure panel.

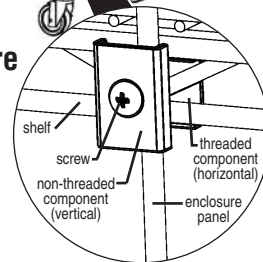

Assembly is complete.

(End)



Profit from the Eagle Advantage®

• 100 Industrial Boulevard, Clayton, Delaware 19938-8903 U.S.A. • www.eaglegrp.com
• Phone: 302/653-3000 • (Foodservice) 800/441-8440 • (MHC/Retail) 800/637-5100
• Fax: 302/653-2065

Eagle Foodservice Equipment, Eagle MHC, SpecFAB®, and Retail Display are divisions of Eagle Group. ©2009 by the Eagle Group