

300 and 400 Series Sinks

INSTALLATION INSTRUCTIONS

CAUTION

INSPECT CONTENTS IMMEDIATELY AND FILE CLAIM WITH DELIVERING CARRIER FOR ANY DAMAGE.
SAVE YOUR BOX AND ALL PACKING MATERIALS.
YOU ARE RESPONSIBLE FOR DAMAGE TO YOUR UNIT IF RETURNED IMPROPERLY PACKED.

BEFORE ASSEMBLY, PLEASE READ:

- Local codes regarding installation vary by location. Installation must comply with all required codes. Contact the authorities in your area having jurisdiction over requirements for installation of this equipment.

CONTENTS INCLUDE:

- (1) Sink Unit *
- (2) Crossbraced Leg Assemblies
- (4) 5/16-24 Set Screw
- (1) 5/32" Allen Wrench
- (1) Installation Instructions
- Drain(s)** , 1-1/2" NPS - with coupling nut, gasket, and sealing washer

Remove contents from crate. Verify that all contents listed above are included. Consult the factory, the factory representative or Eagle's authorized service center in your area if parts are missing.

* Sinks with optional downturn backsplash are provided with Z-brackets.

** Quantity of drains depends on quantity of sink bowls included with sink ordered.

Step 1 - Attach leg assemblies.

- Place sink upside down as shown in illustration.
- Insert the top of both legs into front and rear gussets.
- Using allen wrench provided, secure leg assembly into gussets with set screws (see *figure 1*) —one screw per gusset.
- Fill the head of the set screw with NSF-approved sealant. Remove excess and smooth.
- Repeat on remaining end of unit.
- Place sink in its upright position (might require assistance).

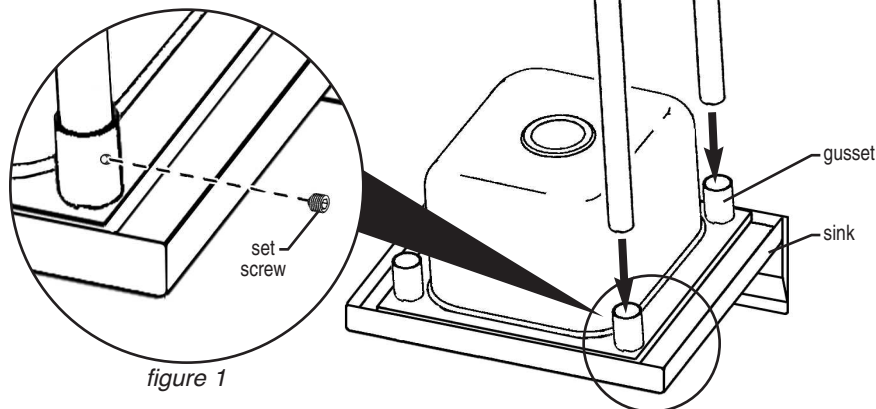

Step 2 - Install drain(s) and faucet(s), provided separately.

Follow instructions provided with hardware for installation.

(continued on page 2)

EG10001 Revised 12/12

300 and 400 Series Sinks

INSTALLATION INSTRUCTIONS

Step 3 - Level sink.

- Place sink in the intended installation location.
- Level sink by turning adjustable bullet foot (see *figure 3*) on each leg.

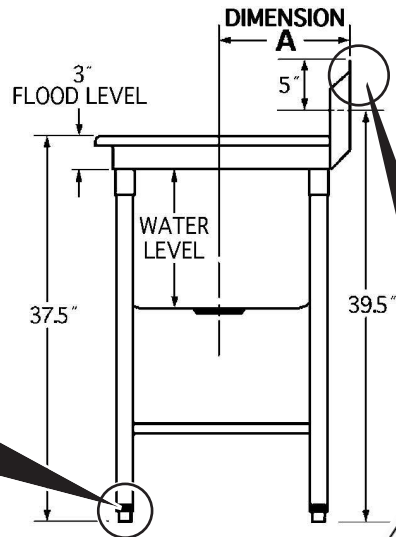
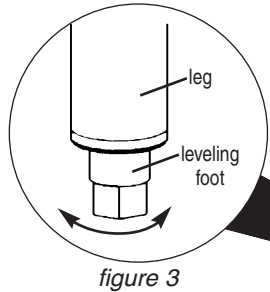

Step 4 - Plumb drain(s) and water supply lines, referring to chart below and illustration at left.

Drain location from backsplash

bowl size (inches)	DIMENSION A (inches)
20" x 16"	14"
24" x 18"	16"
22" x 22"	15"
24" x 24"	16"

Step 5 - Secure and seal unit to wall as required.

For NSF approval:

- Apply silicone sealant along the topmost flange of backsplash, or...
- Cover topmost flange with finished wall.

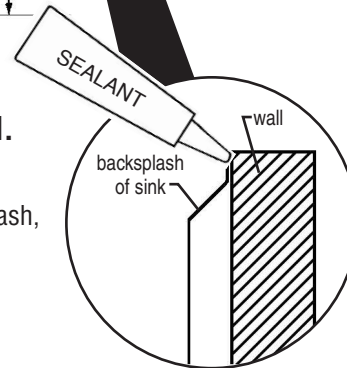

Step 6 - Flush system and check for leaks.



CLEANING INSTRUCTIONS

Properly cared for, sink will last indefinitely. Improper use of commercial chemicals, sterilizers, and detergents may cause corrosion, discoloring, and pitting. For best results, follow these recommendations:

- You must clean sink thoroughly and flush with water after using detergent and sterilizers.
- NEVER LEAVE SOLUTIONS IN SINK OVERNIGHT.
- Use solutions ONLY IN STRENGTH RECOMMENDED BY MANUFACTURER, or they may cause severe damage. High content of chlorine, chlorine derivatives, or bleach are not recommended for stainless steel bowls, for they cause pitting or corrosion.
- Avoid spillage or splashing of full-strength chemicals directly onto stainless steel surface. Always put water in sink before adding sanitizing agents or soaps.
- Between cleanings, wipe the stainless steel sink with a damp cloth. Deposits of dirt or grease in sinks provide local points of attack.
- CAUTION: NEVER USE ORDINARY STEEL WOOL. Use only stainless steel wool or scouring pads.
- DO NOT USE steel scrapers to clean stainless steel.

NOTE: A discoloration may show at the seams, which is SURFACE RUST. It may be caused by the iron in your water or strong detergents. CLEAN AT ONCE with any good strong cleanser.



- 100 Industrial Boulevard, Clayton, Delaware 19938-8903 U.S.A. • www.eaglegrp.com
- Phone: 302/653-3000 • (Foodservice) 800/441-8440 • (MHC/Retail) 800/637-5100
- Fax: 302/653-2065