



Profit from the Eagle Advantage®

Specification Sheet

Short Form Specifications

Eagle Q-LEVER® Cantilever Add-On Shelving, model _____, 5-Tier add-on units feature one 76"-high upright and all-wire shelves. Maximum accessibility and productivity. No wall bolting required. Upright utilizes adjustment in 2" increments without the use of tools. Shelves offered with Valu-Master® gray or Valu-Gard® green epoxy finish. Valu-Master® gray epoxy on upright.



Options / Accessories

- Wall Grids
- Hanger Rails
- Supply Bins
- Storage Baskets
- 36", 56", 66", or 86" optional height.

EAGLE GROUP

100 Industrial Boulevard
Clayton, DE 19938-8903 USA

Phone: 302-653-3000 • 800-441-8440

Fax: 302-653-2065

www.eaglegrp.com • www.eaglemhc.com

For custom configuration or fabrication needs, contact our SpecFAB® Division.

Phone: 302-653-3000 • Fax: 302-653-2065 • e-mail: quotes@eaglegrp.com

Item No.: _____
 Project No.: _____
 S.I.S. No.: _____

Q-LEVER® Cantilever Shelving—5-Tier Add-On Units with Wire Shelves, 76" Height

MODELS:

- | | | | |
|----------------------------------|----------------------------------|----------------------------------|----------------------------------|
| <input type="checkbox"/> Q1824*5 | <input type="checkbox"/> Q2124*5 | <input type="checkbox"/> Q2424*5 | <input type="checkbox"/> Q3030*5 |
| <input type="checkbox"/> Q1830*5 | <input type="checkbox"/> Q2130*5 | <input type="checkbox"/> Q2430*5 | <input type="checkbox"/> Q3036*5 |
| <input type="checkbox"/> Q1836*5 | <input type="checkbox"/> Q2136*5 | <input type="checkbox"/> Q2436*5 | <input type="checkbox"/> Q3042*5 |
| <input type="checkbox"/> Q1842*5 | <input type="checkbox"/> Q2142*5 | <input type="checkbox"/> Q2442*5 | <input type="checkbox"/> Q3048*5 |
| <input type="checkbox"/> Q1848*5 | <input type="checkbox"/> Q2148*5 | <input type="checkbox"/> Q2448*5 | <input type="checkbox"/> Q3054*5 |
| <input type="checkbox"/> Q1854*5 | <input type="checkbox"/> Q2154*5 | <input type="checkbox"/> Q2454*5 | <input type="checkbox"/> Q3060*5 |
| <input type="checkbox"/> Q1860*5 | <input type="checkbox"/> Q2160*5 | <input type="checkbox"/> Q2460*5 | <input type="checkbox"/> Q3066*5 |
| <input type="checkbox"/> Q1866*5 | <input type="checkbox"/> Q2166*5 | <input type="checkbox"/> Q2466*5 | <input type="checkbox"/> Q3072*5 |
| <input type="checkbox"/> Q1872*5 | <input type="checkbox"/> Q2172*5 | <input type="checkbox"/> Q2472*5 | |

* See charts on back page for complete model numbers.

Design & Construction Features

- Includes one 76" upright, two braces, five wire shelves, four pairs of brackets, X-brace assembly, and hardware.
- Cantilevered design improves accessibility and productivity.
- Wall bolting not required.
- Upright utilizes 2" adjustment for shelf and accessory spacing.
- Shelves and accessories can be easily adjusted without tools
- Shelves can be added to the left or right of an existing unit.
- Sizing available:
 - Widths: 18"; 21"; 24"; 30"
 - Lengths: 24"; 30"; 36"; 42"; 48"; 54"; 60"
 - Height (standard): 76"
- Choice of Valu-Master® gray or Valu-Gard® green epoxy finish on the shelves.
- Valu-Master® gray epoxy finish on upright.

Certifications / Approvals



AutoQuotes





Item No.: _____
 Project No.: _____
 S.I.S. No.: _____

Q-LEVER® Shelving—5-Tier Add-Ons with Wire Shelves, 76" Height

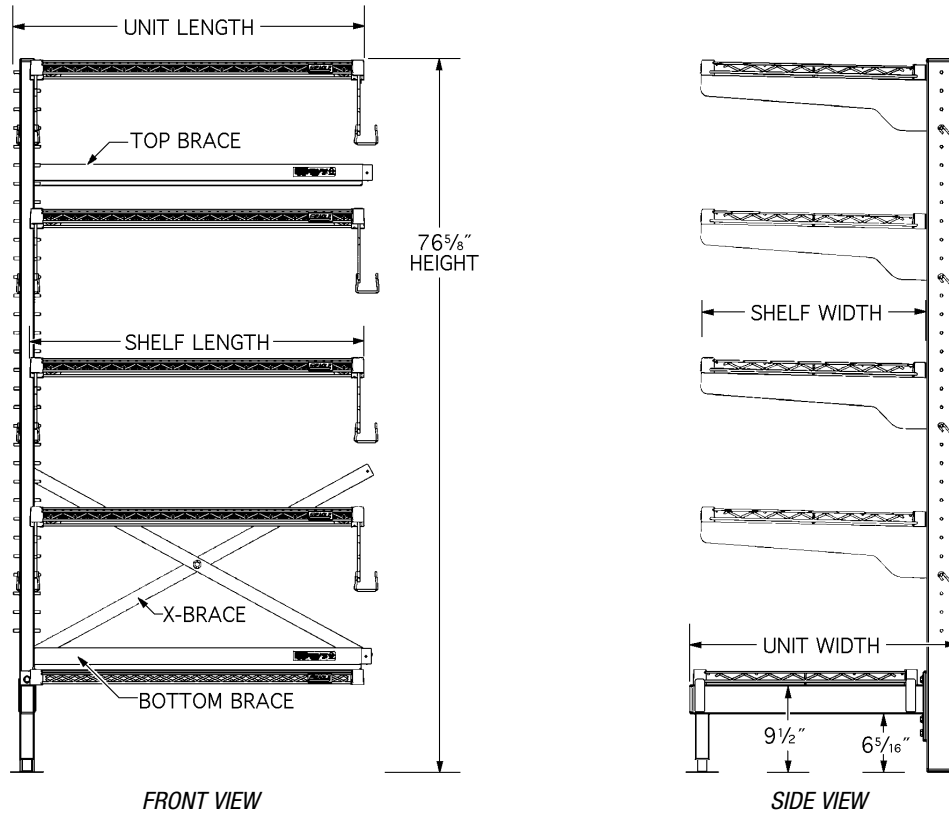

		...WITH 18" (457mm)- WIDE SHELVES *		...WITH 21" (533mm)- WIDE SHELVES *		...WITH 24" (610mm)- WIDE SHELVES *		...WITH 30" (762mm)- WIDE SHELVES *			
shelf length	unit** length	Shelves with Valu-Master® finish	Shelves with Valu-Gard® finish	Shelves with Valu-Master® finish	Shelves with Valu-Gard® finish	Shelves with Valu-Master® finish	Shelves with Valu-Gard® finish	Shelves with Valu-Master® finish	Shelves with Valu-Gard® finish		
in. mm	in. mm										
24"	610	25 1/2"	648	Q1824V76A-5	Q1824VG76A-5	Q2124V76A-5	Q2124VG76A-5	Q2424V76A-5	Q2424VG76A-5	-	-
30"	762	31 1/2"	800	Q1830V76A-5	Q1830VG76A-5	Q2130V76A-5	Q2130VG76A-5	Q2430V76A-5	Q2430VG76A-5	Q3030V76A-5	Q3030VG76A-5
36"	914	37 1/2"	953	Q1836V76A-5	Q1836VG76A-5	Q2136V76A-5	Q2136VG76A-5	Q2436V76A-5	Q2436VG76A-5	Q3036V76A-5	Q3036VG76A-5
42"	1067	43 1/2"	1105	Q1842V76A-5	Q1842VG76A-5	Q2142V76A-5	Q2142VG76A-5	Q2442V76A-5	Q2442VG76A-5	Q3042V76A-5	Q3042VG76A-5
48"	1219	49 1/2"	1257	Q1848V76A-5	Q1848VG76A-5	Q2148V76A-5	Q2148VG76A-5	Q2448V76A-5	Q2448VG76A-5	Q3048V76A-5	Q3048VG76A-5
54"	1372	55 1/2"	1410	Q1854V76A-5	Q1854VG76A-5	Q2154V76A-5	Q2154VG76A-5	Q2454V76A-5	Q2454VG76A-5	Q3054V76A-5	Q3054VG76A-5
60"	1524	61 1/2"	1562	Q1860V76A-5	Q1860VG76A-5	Q2160V76A-5	Q2160VG76A-5	Q2460V76A-5	Q2460VG76A-5	Q3060V76A-5	Q3060VG76A-5
66"	1676	67 1/2"	1715	Q1866V76A-5	Q1866VG76A-5	Q2166V76A-5	Q2166VG76A-5	Q2466V76A-5	Q2466VG76A-5	Q3066V76A-5	Q3066VG76A-5
72"	1829	73 1/2"	1867	Q1872V76A-5	Q1872VG76A-5	Q2172V76A-5	Q2172VG76A-5	Q2472V76A-5	Q2472VG76A-5	Q3072V76A-5	Q3072VG76A-5

* For unit width, add 5 inches to shelf width.
 ** Dimensions are nominal.